

Contents

1. Installation and Operation	1-1
1-1 General installation and operation	1-1
1-2 Precautions when installing the unit	1-2
1-3 Inspection at delivery	1-4
1-4 Installation	1-6
1-5 Making start up easier	1-9
2. Outline of Wiring and Operation	2-1
2-1 Connection of the power supply and servo motor	2-1
2-1.1 Connection systems	2-1
2-1.2 Servo motor connection precautions	2-2
2-1.3 Servo motor terminal details	2-2
2-1.4 Wiring the servo amplifier terminal block	2-5
2-2 Power supply	2-6
2-2.1 Power and main control circuit wiring	2-6
2-2.2 Emergency stop circuit	2-7
2-2.3 Alarm occurrence timing chart	2-7
2-2.4 Electromagnetic brake operation	2-8
2-3 Servo amplifier display operation	2-9
3. Start Up and Operation of Position Servo	3-1
3-1 Wiring	3-1
3-2 Checking wiring	3-1
3-3 Switching power on and setting parameters	3-3
3-4 Operation	3-6
3-5 The display and setting functions	3-7
3-5.1 Display flow chart	3-7
3-5.2 Status display	3-8
3-5.3 Diagnosis mode	3-9
3-5.4 Alarm mode	3-10
3-5.5 Parameters	3-11
3-6 Wiring	3-18
3-6.1 Standard connection diagram	3-19
3-6.2 Common line diagram for position servo	3-21
3-6.3 Interface power supply	3-22
3-7 Explanation of signals	3-23
4. Start Up and Operation of Speed Servo	4-1
4-1 Wiring	4-1
4-2 Checking wiring	4-1
4-3 Switching power on and setting parameters	4-2
4-4 Operation	4-4
4-5 Display and setting function	4-5
4-5.1 Display flow chart	4-5
4-5.2 Status display	4-6

4-5.3	Diagnosis mode	4-7
4-5.4	Alarm mode	4-8
4-5.5	Parameters	4-9
4-6	Wiring	4-19
4-6.1	Standard connection diagram	4-20
4-6.2	Common line diagram for speed servo	4-22
4-6.3	Interface power supply	4-23
4-7	Explanation of signals	4-24
5.	Adjustments and Application Operations	5-1
5-1	Adjustments	5-1
5-1.1	Start-up adjustment sequence	5-1
5-1.2	Automatic tuning	5-3
5-1.3	Adjustment of the loop gain	5-6
5-1.4	Clever usage of the ultracompact HA-ME servo motor	5-9
5-2	Adjustments and application operations	5-10
5-2.1	Rotation trouble display mode	5-11
5-2.2	Do (output signal) check mode	5-12
5-2.3	Test mode operation 1 (operation with no commands)	5-14
5-2.4	Test mode operation 2 (operation without motor)	5-16
5-2.5	Alarm history clear (H2 display)	5-19
5-2.6	Offset adjustment mode (speed servo)	5-20
5-2.7	Check of digital input/output signal (external input/output signal) mode	5-20
6.	Methods for Using the Auxiliary Equipment and Options	6-1
6-1	Regenerative option	6-1
6-2	Dynamic brake option	6-4
6-3	Power factor improvement reactor FR-BAL	6-6
6-4	Cables and connectors	6-7
6-4.1	Options list	6-7
6-4.2	Connector diagrams	6-8
6-4.3	Cable specifications	6-10
6-4.4	Connection diagram for option cables	6-11
6-5	Junction terminal block (Model: A6TBXY36)	6-15
6-6	Electrical wires, breakers and magnetic contactors	6-18
6-7	Selection of relays	6-18
6-8	Selection of the external speed command and external torque limit command potentiometers (pof)	6-19
6-9	Noise reduction techniques	6-20
6-10	Selection of power supply and surge absorber for electromagnetic brake ..	6-25
6-11	Leakage current breaker	6-26
6-12	External power for interface devices	6-27
7.	Setting	7-1
7-1	List of control variables	7-1
7-2	Position resolution and parameter setting	7-2
7-3	Servo motor speed and command pulse frequency	7-4

7-4	Stopping characteristics of the servo motor	7-5
7-5	Servo motor selection	7-6
7-6	Load torque equations	7-9
7-7	Load inertia equations	7-10
7-8	Procedure for setting the mechanical origin	7-11
7-9	Example of servo motor selection	7-12
8.	Troubleshooting	8-1
8-1	Troubles shooting points	8-1
8-2	How to measure the voltage and current of the servo	8-2
8-3	Periodic inspection and maintenance	8-3
8-4	Alarms	8-6
8-5	Determining the cause of a position offset	8-12
9.	Data	9-1
9-1	Torque characteristics	9-1
9-2	Servo amplifier overload protection characteristics	9-3
9-3	Losses generated in servo amplifier	9-4
9-4	Regenerative brake characteristics	9-6
9-5	Electromagnetic brake characteristics	9-9
9-6	Dynamic brake characteristics	9-12
9-7	Mechanical characteristics of the servo motor	9-13
	9-7-1 Vibration rank	9-13
	9-7-2 Flex life of the encoder cable	9-13
9-8	Servo Motor with reduction gear	9-13
	9-8-1 HA-ME series	9-13
	9-8-2 HA-FE series	9-14
	9-8-3 HA-SE series	9-14
9-9	Servo motor with tapered shaft	9-16
9-10	Servo motor with special shaft	9-16
10.	Specifications	10-1
10-1	Model configuration	10-1
10-2	Standard specifications	10-2
10-3	Outer dimensions of servo amplifier	10-5
10-4	Outer dimensions of servo motor	10-6
10-5	Outer dimensions of UL listed and CSA certified servo motor	10-14
10-6	Protective functions	10-22

Installation and Operation	1
Outline of Wiring and Operation	2
Start Up and Operation of Position Servo	3
Start Up and Operation of Speed Servo	4
Adjustments and Application Operations	5
Methods for Using the Auxiliary Equipment and Options	6
Setting	7
Troubleshooting	8
Data	9
Specifications	10

5. Adjustments and Application Operations

5-1 Adjustments

5-1.1 Start-up adjustment sequence

The following table lists faults, checks and actions corresponding to the steps of the servo start-up sequence. The alarm codes are shown below as they would be displayed on the servo amplifiers LED display.

No.	Start-up sequence	Fault	Check/action	Assumed cause	Refer to:	
1	Power ON	<ul style="list-style-type: none"> LED is not lit. LED flickers. 	Not improved by disconnecting connectors CN1, CN2.	Servo amplifier failure	—	
			Improved by disconnecting connector CN1.	Power supply of the CN1 cable is shorted.		
			Improved by disconnecting connector CN2.	1) Power supply of the CN2 cable is shorted. 2) Encoder failure		
		Alarm occurs	AL-12, 15, 17	Disconnect connectors CN1, CN2.	If not improved, the amplifier has failed.	Section 8-4
			AL-37	Check ALP <input type="checkbox"/> <input type="checkbox"/> (parameter number).		
			AL-10	Check the power supply voltage.	Power supply voltage low.	
			AL-16	Check the CN2 cable for disconnection.	1) CN2 cable connection fault 2) Cable disconnection, servo amplifier failure, encoder failure	
AL-30	Check the power supply voltage.		1) Power supply voltage too high. 2) If the power supply voltage is normal, the servo amplifier has failed.			
AL CPU AL CO	Switch the power off, then on.	If not improved, the servo amplifier has failed.				
2	Switch on the servo ON signal.	Alarm occurs.	AL-32	Disconnect cables from the servo amplifier output terminals (U, V, W) and switch on the servo.	1) If not improved, the servo amplifier has failed. 2) If improved, a short circuit or ground fault has occurred in the wiring or servo motor.	Section 8-4
			AL-50	<ul style="list-style-type: none"> Check the status display (peak load ratio b). It is about 300 as soon as the servo is switched on, and the alarm occurs in 1 to 2 seconds. Motor shaft moves slightly and is then locked. 	1) Servo amplifier output terminal (U, V, W) wiring fault 2) Encoder wiring fault	Section 3-5 Section 4-5 Section 8-4
				<ul style="list-style-type: none"> Servo motor shaft oscillates. The alarm occurs in several to several ten seconds. 	1) Load inertia is large and servo is instable. (a) Execute auto tuning. (b) Set the position loop gain (parameter No. 5 or No. 11) to "7". (Make servo gain adjustment.)	
		Not servo locked. (The motor shaft is free.)	<ul style="list-style-type: none"> Check the rotation trouble display or external I/O signal display. 	(a) Servo ON signal is not input (wiring fault) (b) VIN and VDD are not connected.	Section 3-5 Section 4-5 Section 5-2.1	
			With the servo OFF, turn the servo motor shaft and check the cumulative feedback pulses.	If a change of 4000 pulses does not occur after one revolution of the servo motor, the encoder has failed or cable wiring is faulty.		

5

5. Adjustments and Application Operations

No.	Start-up sequence	Fault	Check/action	Assumed cause	Refer to:
3	Input the position (speed) command. (Test run)	Servo motor does not rotate.	<ul style="list-style-type: none"> • Check the rotation trouble display. 	1) Wiring fault (a) VIN and VDD are not connected.	Section 3-5 Section 4-5 Section 5-2.1
			1) Position servo: Check the cumulative command pulse P display.	1) Wiring fault (a) VDD and OP are not connected. 2) Pulses are not input.	
			2) Speed servo: Check the speed command voltage F display.	1) Wiring fault 2) Speed command (analog) is not input.	
4	Make gain adjustment.	Rotating ripples (speed fluctuation) is large at low speed.	Make gain adjustment with the following procedure: 1) Decrease the setting of the speed integral compensation (Pr. 13). (The limit value is "10" or where the machine begins to make a sound.) 2) Increase the setting of the speed loop gain (Pr. 12). (The limit value is where the machine begins to make a sound.)	Gain adjustment fault	Section 5-3.1
		Load inertia is large and the servo motor oscillates.	Make gain adjustment with the following procedure: 1) Execute auto tuning or set the position loop gain to "7". 2) Increase the setting of the speed loop gain (Pr. 12). (The limit value is where the machine begins to make a sound.) 3) Gradually increase the setting of the position loop gain (Pr. 5 or Pr. 11). (The limit value is where overshooting begins to occur at a stop.)	Gain adjustment fault	Section 5-1.3
5	Cyclic operation	Position offset occurs. (Position servo)	Check the controller's output counter command pulse value (P) and feedback pulse value (C) and the actual servo motor position.	Pulse count error, etc. due to noise	Section 8-5

5. Adjustments and Application Operations

5-1.2 Automatic tuning

First, confirm the setting details in parameter 1.

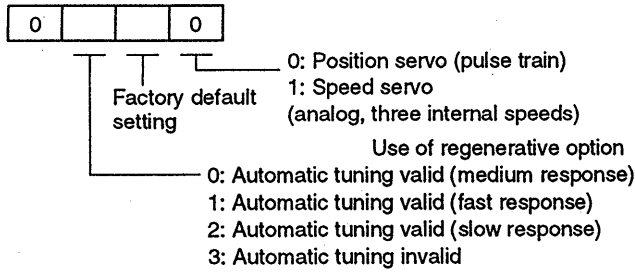

First, execute the automatic tuning with the medium response set as the factory default setting to confirm the operation.

If there is no problem, use the medium response, or set to fast response and confirm the operation.

If there is a problem, set to slow response and confirm.

If there are still problems, set to the manual setting.

According to machine inertia (rigidity) or drive method, guidelines for fast, medium and slow response.

Drive method		Fast response	Medium response	Slow response	
Horizontal drive	Ballscrew	Direct coupling	○		
		With speed reducer		○	
	Rack and pinion	Direct coupling		○	
		With speed reducer		○	
	Timing belt	Direct coupling		○	
		With speed reducer		○	
	Chain	Direct coupling			○
		With speed reducer			○
	Roll feed	Direct coupling	○		
		With speed reducer	○		
	Automated guided vehicle	Direct coupling			○
		With speed reducer			○

Note: In vertical drive applications gain adjustment should be made manually.

In executing automatic tuning:

- 1) Use the acceleration/deceleration times between 50ms and 5s.
- 2) Always use the type acceleration/deceleration command pattern.
- 3) Set the speed to 500r/min or higher.

(Operation method)

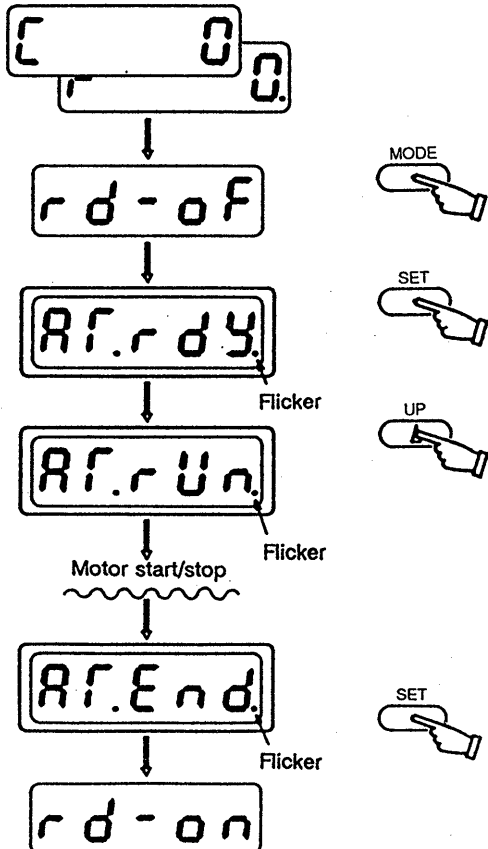

About 5 seconds after the power is switched ON, the status display will be shown.

0: Position servo

1: Speed servo

- Select the display for the diagnosis setting.

- Press the "SET" button for two seconds or more.

- The ready screen "ATrdy" will be displayed.

- The tuning screen "AT.run" will appear when the "UP" button is pressed.

- Switch the servo ON, apply an external command, and start and stop the motor.

- Tuning will end, and "ATEnd" will be displayed. Press the "UP" button to try again.

- The original screen will be displayed when the "SET" button is pressed for two seconds or more.

5. Adjustments and Application Operations

(Timing chart for automatic tuning operation)

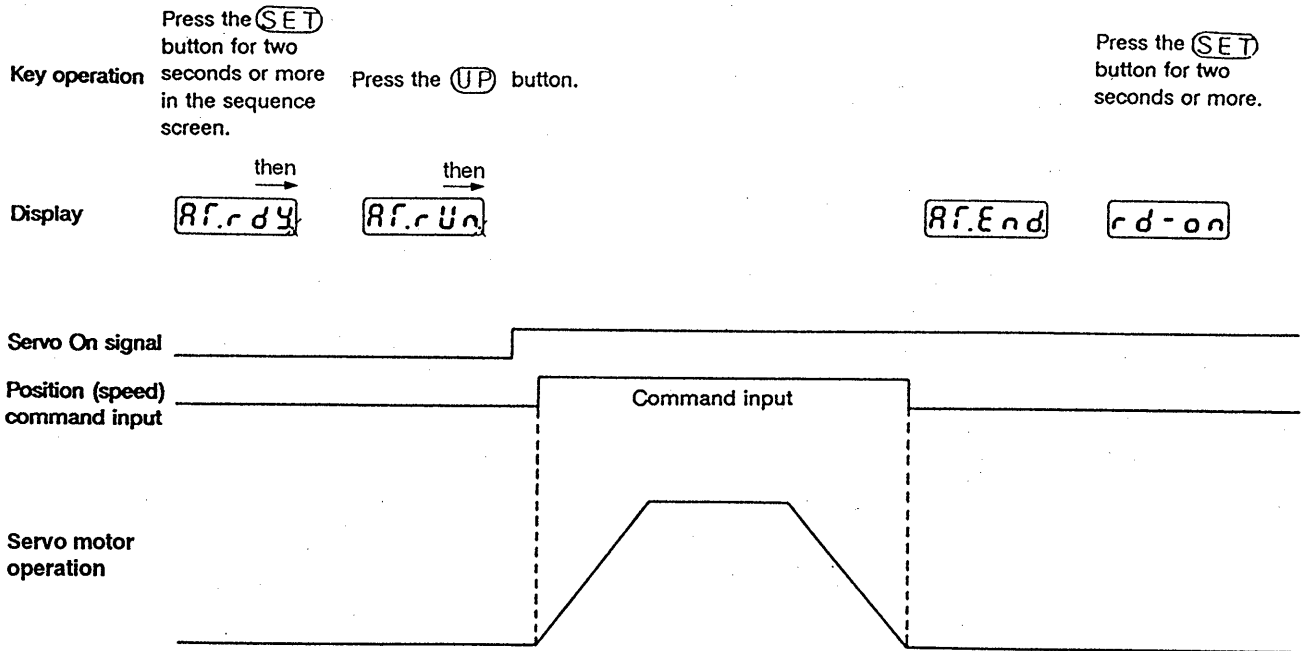

Explanation:

<p>The automatic tuning screen is displayed.</p>	<p>The unit enters automatic tuning mode.</p>	<p>When the position (speed) command is input, the actual motor current (speed) and operation simulator current (speed) will be compared, and the inertia of the load directly coupled with the motor will be estimated.</p>	<p>When the servo motor stops, the parameters for the optimum position loop gain (PGN), speed loop gain (VGN), and speed integral compensation (VIC) will be set according to the of load inertia, and the automatic tuning mode will end.</p>
<p>The screen will return to the sequence screen.</p>			

5. Adjustments and Application Operations

Position (speed) command for automatic tuning

Automatic tuning requires a position (speed) command to initiate automatic tuning. Choice of inputs and required conditions are as specified below.

(1) Input of the position (speed) command for using automatic tuning

- 1) For positioning servo, use:
 - Pulse train position command
- 2) For speed servo, use:
 - External analog speed command
 - Internal three speed commands
- 3) Test mode operation 1 (operation without command)

(2) Conditions of position (speed) command input

- 1) The acceleration/deceleration time is between 50ms and 5s (the acceleration and deceleration times may differ.)

Set the acceleration/deceleration time so that the servo motor acceleration/deceleration torque is less than the maximum torque within the above range.

- 2) A trapezoid acceleration/deceleration is made at the operation speed of 500r/min or more.
- 3) The operation speed is constant 0.5s or more. (With the positioning servo, if the position loop gain (PGN) is less than the initial value of 25 before automatic tuning, the top speed must be constant 0.5s or more.)

4) Caution

Perform auto tuning with the servo motor shaft coupled to a load. If auto tuning is performed without a load (servo motor alone), the following may occur:

- a. Auto tuning is not completed; or
- b. The result of auto tuning will be faulty and the servo motor shaft will be oscillated and instable.

In such a case, stop the auto tuning and set each gain manually. (Refer to Section 5-1.3.)

(3) If a position (speed) command input with conditions other than those above is applied:

- 1) Automatic tuning will not be completed (the display will remain as **Rf.rUn** and will not switch to **Rf.End**).
- 2) The parameter (PGN, VGN, and VIC) set values will not be the optimum values.

(4) Machine conditions for automatic tuning

In the following machines, correct gains may not be obtained even when automatic tuning is executed.

- 1) Machines with fluctuating load inertia or load torque.
- 2) Machines with large backlash.
- 3) Machines with low rigidity, or where mechanical resonance occurs easily.

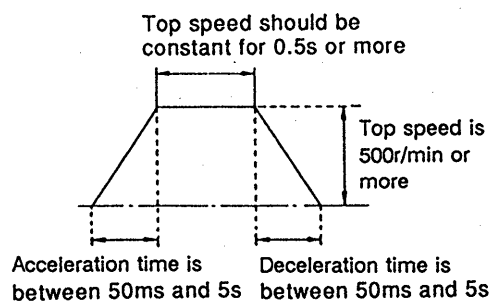

5. Adjustments and Application Operations

5-1.3 Adjustment of the loop gain

The servo amplifier has gain parameters for adjusting its operation. Normally, stable operation can be obtained with automatic tuning. However, if the load is large, or undesirable vibration or noise occur during operation, adjust the parameters to obtain the best performance. Refer to the following explanation when adjusting the parameters.

When vibration and noise occur during operation

In most cases, the servo gain set does not match the load. Follow the procedure below to set the parameters.

(1) Parameters for adjustment and their features

The related parameters and guidelines for setting values are indicated. The initial setting is designed to be optimum for J_L/J_M . If the load is large and vibration and noise occur, make setting after checking the following adjustment method:

1) Position loop gain (PGN)

The position loop gain specifies the number of droop pulses in the position deviation counter during operation. If the PGN is high, the droop pulses will decrease, and the setting time while the motor is stopped can be decreased. If this is set too high, undershooting or vibration during stopping may occur.

If only the PGN is increased when the load inertia ratio is large, the control system will be unstable, and vibration will occur. Set after adjusting the speed loop gain.

For general machines, set PGN to about 35. For machines with a large load inertia, reduce the PGN. To decrease the positioning settling time, increase the PGN. Note that the limit value is a setting where undershooting occurs.

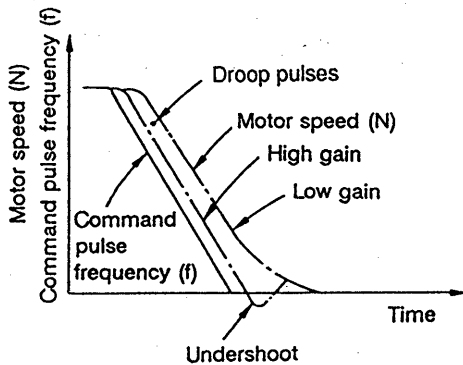

(Remarks) Position loop gain and droop pulses
The droop pulses during operation can be represented by the following equation with the speed and position loop gain.

$$\varepsilon = \frac{f}{K_p} \dots \dots \dots (5-1)$$

- Here, ε : number of droop pulses (pulse)
 f : command pulse frequency (pps)
 K_p : position loop gain (rad/s)

When K_p is increased too much, the motor will vibrate. When K_p is lowered too far, the droop pulses will increase, and an alarm (AL52 excessive difference) will occur during high speed operation.

5. Adjustments and Application Operations

2) Speed loop gain (VGN)

If the load inertia ratio (J_L/J_M) is too large, the speed response of the control system will be lower, and will be unstable. Generally, increase the speed loop gain (VGN). If the VGN is increased too much at this time, vibration (abnormal noise) will occur during operation and stopping. This value is the limit value of the VGN. In consideration of the machine's variations and age, set the VGN to a value 50 to 80 smaller than the limit value. The servo motor speed and waveform relative to the step input of a 1V speed command can be observed by using the monitor output as shown below:

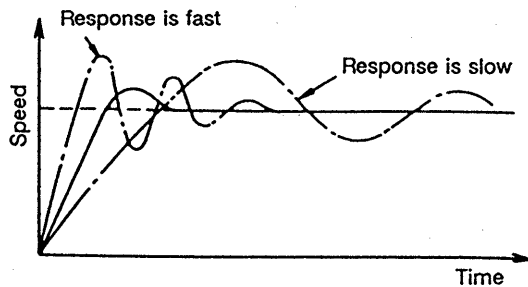

3) Speed integral compensation (VIC)

This is used to increase the frequency response of the speed control loop to improve the transient characteristics. For example, if the overshoot during acceleration/deceleration does not decrease with the VGN setting, the VIC setting can be increased. Also, when speed fluctuation or the like is large, setting the VIC setting can be decreased.

(2) Observation of signal

Display the servo motor speed on an oscilloscope, etc. Use the check pin speed monitor to display the speed feedback signals. The Cathode-ray oscilloscope should be isolated from ground, and make sure that the probe does not contact other connector pins.

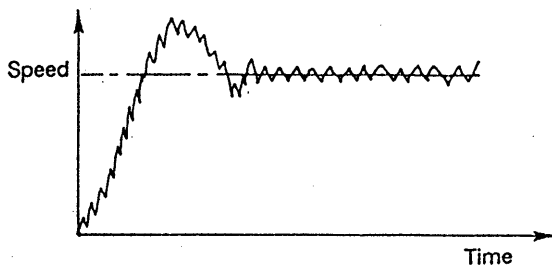
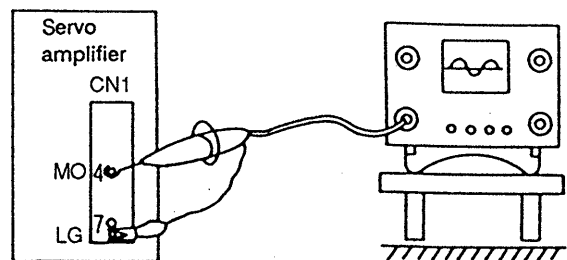

Note: The speed feedback signal (speed monitor) viewed on the oscilloscope may have ripples of short durations as shown on the left. These ripples are produced because of the PWM system used for monitor output.

5. Adjustments and Application Operations

(3) Adjustment procedures

1) General adjustment

- a. Gradually increase the speed loop gain VGN (Pr. 12) and set a value about 50 to 80 smaller than a point where machine vibration occurs (gear noise increases).
- b. Generally, the position loop gain PGN (Pr. 5 or Pr. 11) may remain unchanged from the initial value and need not be adjusted.

Note that the position loop gain should be decreased when the load inertia is large and overshooting at a stop is not eliminated when the setting in above a. is executed.

2) To reduce the speed fluctuation of the motor at low speed

- a. Gradually decrease the speed integral compensation VIC (Pr. 13) and set a value about 5 larger than a point where machine vibration occurs (gear noise increases).
- b. Make adjustment as described in above 1).

3) When the servo motor oscillates at noticeably low frequency (4 to 6 times/second) at the time of servo ON (When the load inertia is much greater than the servo motor inertia):

- a. Set the position loop gain PGN (Pr. 5 or Pr. 11) to "7".
- b. Make adjustment as described in above 1) a.
- c. Gradually increase the position loop gain and set a value smaller than at a point where undershooting occurs at a stop.

4) To reduce the positioning settling time to improve stopping performance (This adjustment may only be made when the load inertia is not much greater than the servo motor inertia):

Make adjustment as described in above 1) a. Especially when the position loop gain PGN is increased, the positioning settling time can be reduced.

5. Adjustments and Application Operations

5-1.4 Clever usage of the ultracompact HA-ME servo motor

The ultracompact HA-ME servo motor is designed with an extremely small inertia to provide a high power rate. If a machine is designed to have a small inertia, therefore, it can operate with high performance. However, if the machine cannot be designed to have a small inertia, note the following:

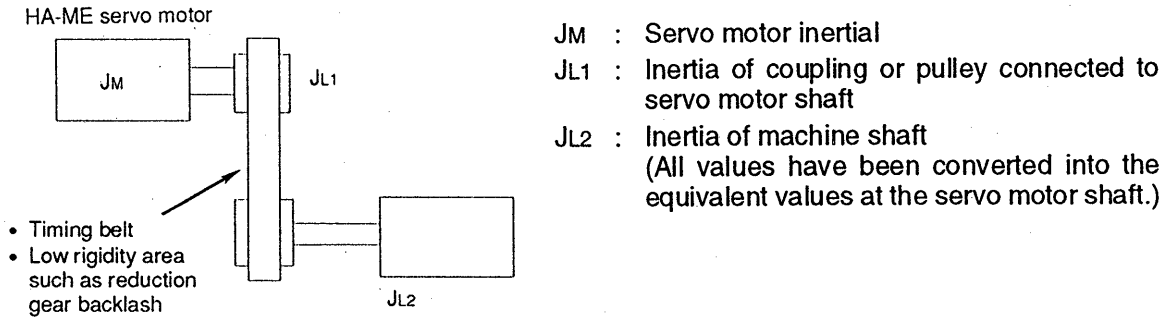

Design the machine to satisfy the following expressions:

- 1) $\frac{JL1+JL2}{JM} \leq 30$ Recommended load inertia
- 2) $\frac{JL2}{JM+JL1} \leq 8$

Note: The smaller the above values, the higher the performance of the system.

After installing the servo to the machine, gradually increase the setting of parameter No. 12 (speed loop gain) and set a value "50" to "80" smaller than a point where the machine begins to make a sound.

5. Adjustments and Application Operations

5-2 Adjustments and application operations

Functions that are handy during start up, such as test operation and automatic tuning, can be used in the diagnosis mode.

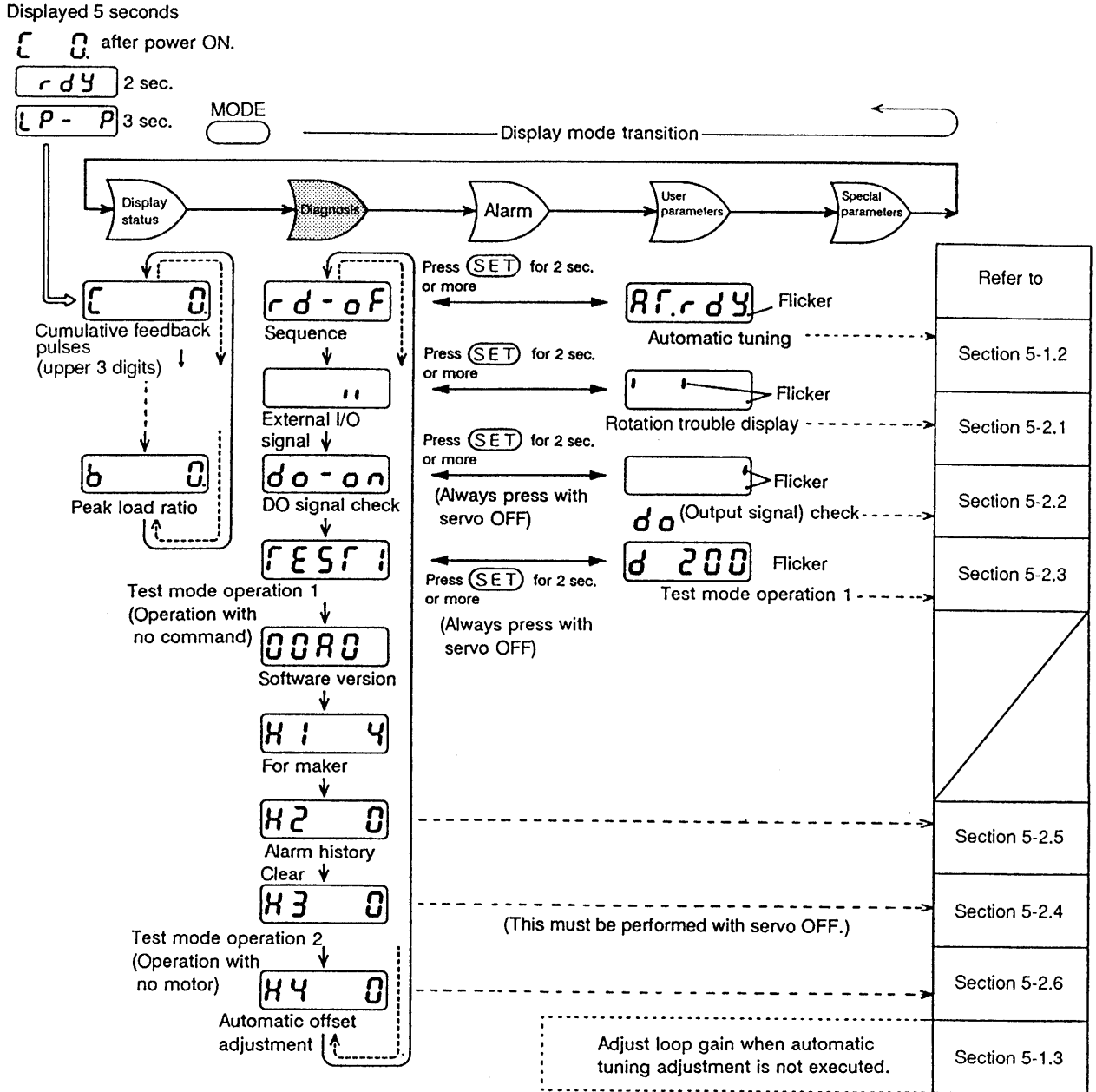

5. Adjustments and Application Operations

5-2.1 Rotation trouble display mode

When the servo motor does not rotate, the reason will be displayed by the flickering LED segments. Check the input conditions on this display when the servo motor does not rotate.

(1) Operation procedure

1) How to select the rotation trouble display

- Select the external signal screen with the MODE, UP, and DOWN buttons.
- Press the SET button for two seconds or more.

2) How to exit the rotation trouble display

- Press SET for two seconds or more. The external signal screen will be displayed.

(2) Rotation trouble screen

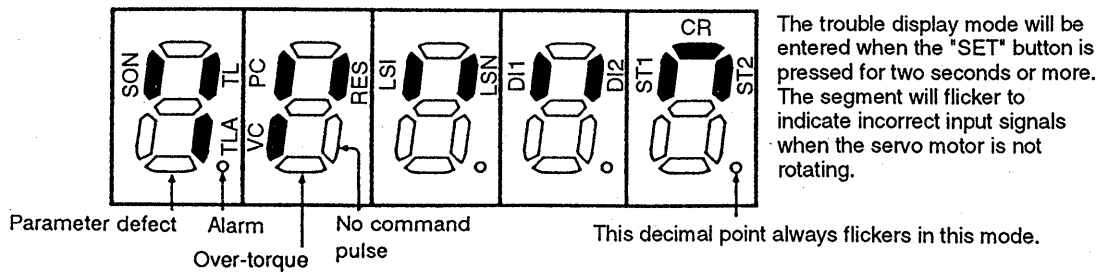

If the LED segment is flickering, the reasons for the servo motor not rotating can be determined from the following chart.

Flickering segment	Reason for not rotating	Positioning servo/ speed servo
SON	SON signal is not ON.	Positioning/speed
RES	The RES signal is not OFF.	Positioning/speed
LSP, LSN	The LSP is not ON during forward run. The LSN is not ON during reverse run.	Positioning
ST1, ST2	Both ST1 and ST2 are ON or both are OFF.	Speed
No command pulse	The command pulse is not input. (This will also flicker if the frequency is low (approximately 1kpps or less).)	Positioning
VC	Both DI1 and DI2 are off, and the external analog speed command is 0V.	Speed
Parameter defect	The internal three speeds are set with DI1 and DI2, and the parameter value is zero.	Speed
TL, TLA over-torque	The machine struck something, the load torque is too large, or the torque limit value is smaller than the load torque.	Positioning/speed
Alarm	An alarm has occurred. • If an alarm occurs when this screen is displayed, the current alarm screen will be displayed forcibly. If this screen is displayed when an alarm has occurred, the alarm segment will flicker.	Positioning/speed

The segments in this screen will flicker when the servo motor is not rotating. Therefore, even when the servo motor is rotating normally, if the servo motor is stopped with input conditions, the segment corresponding to that input condition will flicker. The segments may also flicker temporarily during the motor acceleration/deceleration, etc.

5. Adjustments and Application Operations

5-2.2 Do (output signal) check mode

This mode is used to forcibly switch each output signal ON or OFF regardless of the servo's conditions. Use this to check the wiring of the servo amplifier.

(1) do (output signal) check screen

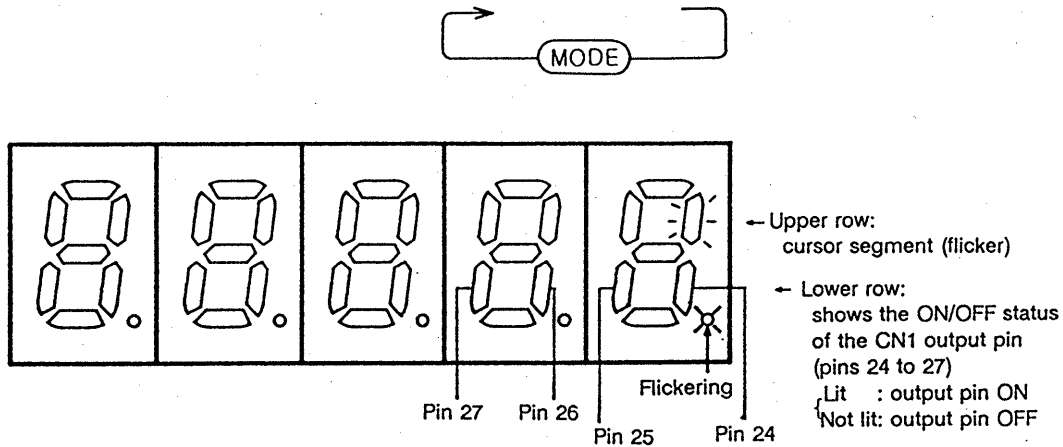

Definition of keys

Name of keys	Definition
MODE	The cursor segment is moved to the left.
UP	The lower row of the cursor segment lights and the CN1 output pin switches ON.
DOWN	The lower row of the cursor segment goes out and the CN1 output pin switches OFF.
SET (Two seconds or more)	The screen returns to the do-on display. Nothing will change if not pressed for two seconds or more.

Assignment of output pins

Output pin No.	Functions of the CN1 output pins			
	Positioning servo		Speed servo	
24	Ready (RD)		Ready (RD)	
25	Positioning complete (PF)	Limiting torque (TLC) can also be selected with Pr. 19.	Speed reached (PF)	Limiting torque (TLC) can also be selected with Pr. 19.
26	Zero speed (ZSP)		Zero speed (ZSP)	
27	Trouble (ALM)		Trouble (ALM)	

5. Adjustments and Application Operations

(2) Operation procedure

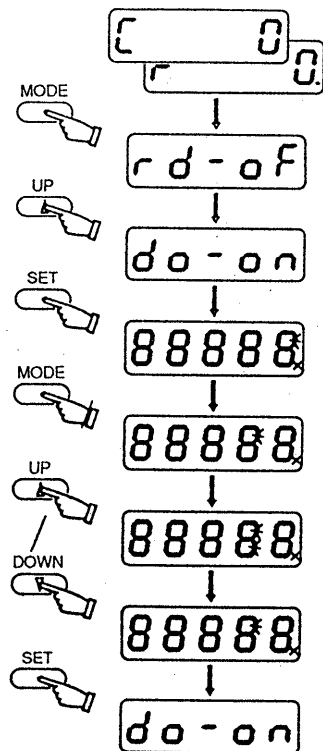

About 5 seconds after the power is switched ON, the status display will be given.

[0] : Position servo
r 0 : Speed servo

- Select the do (output signal) check display "do-on" with the "MODE and UP" buttons.
- Press the "SET" button for two seconds or more.
- Press "MODE" to select the pin of the desired output to be switched on.
- When (CN1 pin 26) has been selected:
- Switch ON the output pin (CN1 pin 26) with the "UP" button.
- Switch OFF the output pin (CN1 pin 26) with the "DOWN" button.
- Select "do-on" by pressing the "SET" button for two seconds or more.

Note:

- When selecting the do (output signal) check screen, always switch the servo OFF.
- When the do (output signal) check screen is selected, all output signals will be set to OFF.

5. Adjustments and Application Operations

5-2.3 Test mode operation 1 (operation with no commands)

This mode allows the servo motor to be rotated without connecting connector CN1.

(Operation procedure)

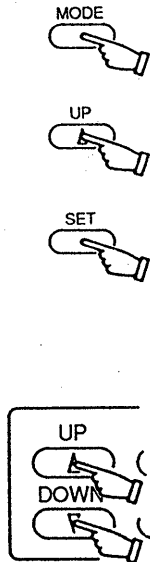
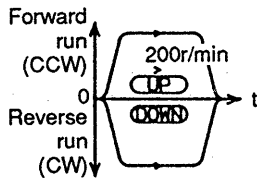
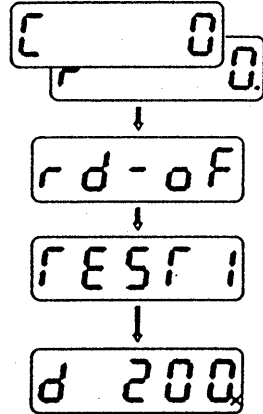

About 5 seconds after the power is switched ON, the status display will be given.

[] : Position servo

r] : Speed servo

- Display "TEST1" in the test operation screen with the "MODE and UP" keys.

- Press the "SET" key for two seconds or more.

- Test operation can be done in the approximately 0.7 seconds acceleration/deceleration time with the "UP and DOWN" keys.

- The motor will rotate while the "UP" or "DOWN" key is pressed.

The acceleration/deceleration time constants can be changed by changing the data in the corresponding parameters.

However, the value will be 0.5 seconds longer.

(Changing the rotation speed)

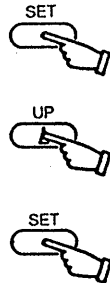
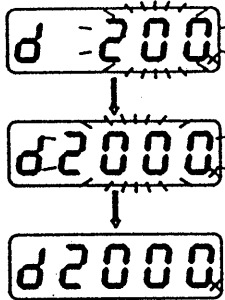

- 200 will flicker with the "SET" key.

(The "SET" key must be pressed for less than two seconds.)

- Set to the desired speed with the "UP and DOWN" keys.

- The speed can be set to 2000r/min with the "SET" key.

Definition of keys

Name of keys	Definition	
MODE	The test mode operation status display will change.	
UP	When the data value in the set rotation speed display screen is flickering, the set speed will increase.	
		The servo motor will rotate forward (CCW) when other than above.
DOWN	When the data value in the set rotation speed display is flickering, the set speed will decrease.	
		The servo motor will rotate reverse (CW) when other than above.
SET		Use to change the set value in the set rotation speed display, when pressed for less than two seconds in the set rotation speed display.
		Return to the test operation display "TEST1" (top screen), when pressed for two seconds or more.

5. Adjustments and Application Operations

Note

- The servo ON signal must be OFF when switching to the test operation mode or leaving the test operation mode.
- For the positioning servo, there may be a maximum of 20r/min deviation between the set rotation speed and actual rotation speed.
- The acceleration time for the positioning servo in test operation will be the value set in Pr. 10 plus 0.5 seconds. For the speed servo, the acceleration/deceleration time will be the value set in Pr. 5 and 6 plus 0.5 sec. S-character acceleration/deceleration is not possible.

5. Adjustments and Application Operations

5-2.4 Test mode operation 2 (operation without motor)

This mode is used to output the output signals and to display the status in the same way as when the motor is rotating, without connecting the servo motor.

The upper programmable controller (PC) sequence can be checked without connecting the servo motor.

(1) Operation method

To enter mode for operation without motor

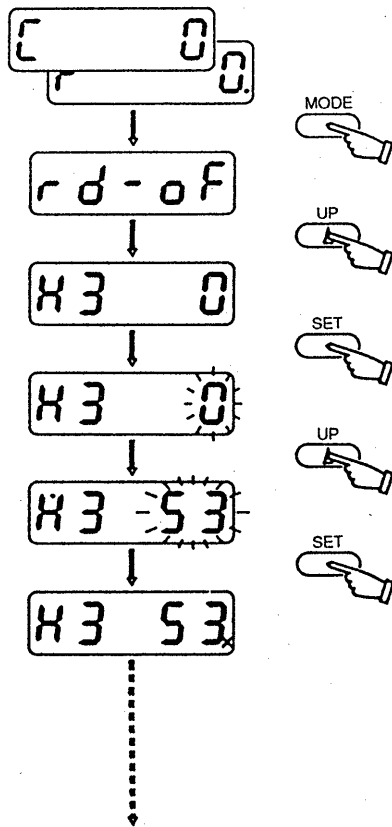

About 5 seconds after the power is switched ON, the status display will be given.

⌈ 0 : Position servo

r 0 : Speed servo

- Select the operation without motor setting display "H3 0" with the "MODE and UP" keys.
- "0" will flicker when the "SET" key is pressed.
- Using the "UP" key, set the data value so that "53" flickers.
- When the "SET" key is pressed, the decimal point of the lowermost digit will flicker, and the mode for operation without motor will start.
(Always carry out the above with the servo ON signal OFF.)

- If the servo ON signal is input and the same command as for rotating the servo motor is input, the output signal will be output accordingly. The speed and cumulative feedback pulses can be viewed in the status monitor display.
(The screen operation is the same as for standard operation.)

To leave this mode

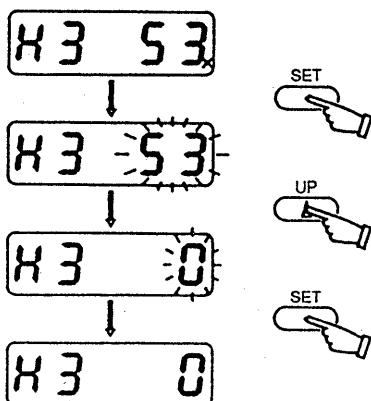

- Call out the operation without motor setting mode "H3 53" with the "MODE and UP" keys.
- "53" will flicker when the "SET" key is pressed.
- Using the "DOWN" key, set the data value to one other than "53".
- When the "SET" key is pressed, the decimal point of the lowermost digit will go out, and the mode for operation without motor will be left.
(Always carry out the above operation with the servo ON signal OFF.)

(The mode for operation without motor will be exited when the power is switched off.)

5. Adjustments and Application Operations

(2) Precautions

- 1) Operation in this mode without the motor wiring (terminal block U, V, W) and encoder wiring (connector CN2), and when the power is switched ON without the connector CN2, an alarm will be output (AL-16 polarity detection error). Therefore, make sure that the servo amplifier power will not switch OFF even when an alarm is output from the servo amplifier, as shown below.

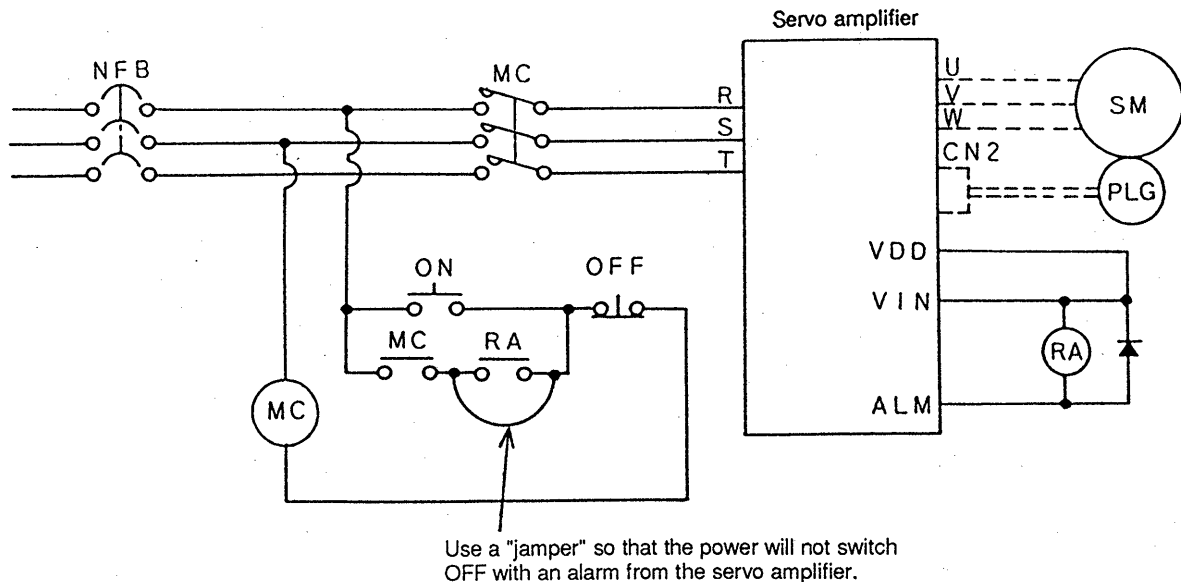

When entering this mode without CN2, the decimal point of the uppermost digit on the operation display explained on the previous page, will flicker to indicate an alarm (AL-16). However, the moment that "53" is set by pressing the **[SET]** button in the H3 screen the alarm (AL-16) will be reset, and the flickering of the decimal point of the uppermost digit will go out.

- 2) Differences between operation without motor and actual motor operation
In the operation without motor, the operation will be simulated with the load torque zero and the load inertia being the same as the servo motor inertia. The output signals and data for status display will be created. Therefore, the following points will differ from actual servo motor operation.
 - Acceleration/deceleration time when step acceleration/deceleration is executed.
 - Effective torque and peak load ratio display values
 - The regenerative load will always be zero.
 - The A-phase, B-phase, Z-phase, and PLG pulse output (FPA, FPB, OP) will not be output.
Consider this when a circuit uses a PLG pulse output to form a closed loop.
- 3) Always enter and leave this mode motor when the "servo ON" signal is OFF. (AL90 will occur if the unit enters or leaves the mode with the "servo ON" signal ON.)
- 4) Before entering this mode, set the parameters of position loop gain, speed loop gain, and speed integration compensation to the factory setting (initial values).

5. Adjustments and Application Operations

(Test operation status display)

- Speed servo

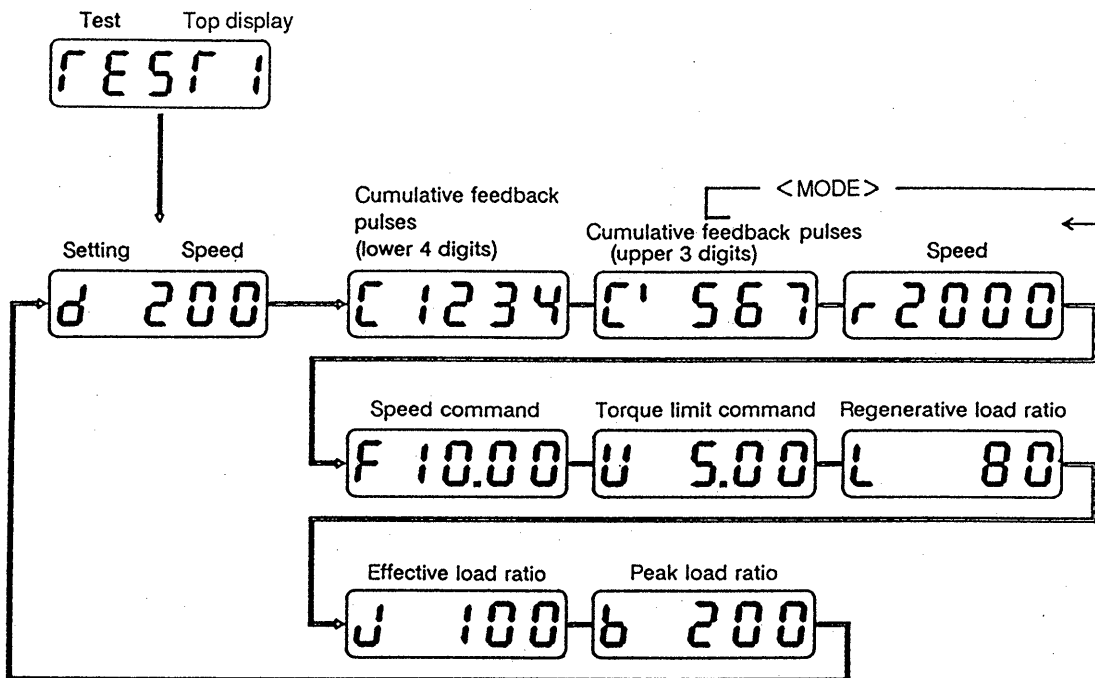

The set speed will be 200r/min when switched to the test operation screen.

- Positioning servo

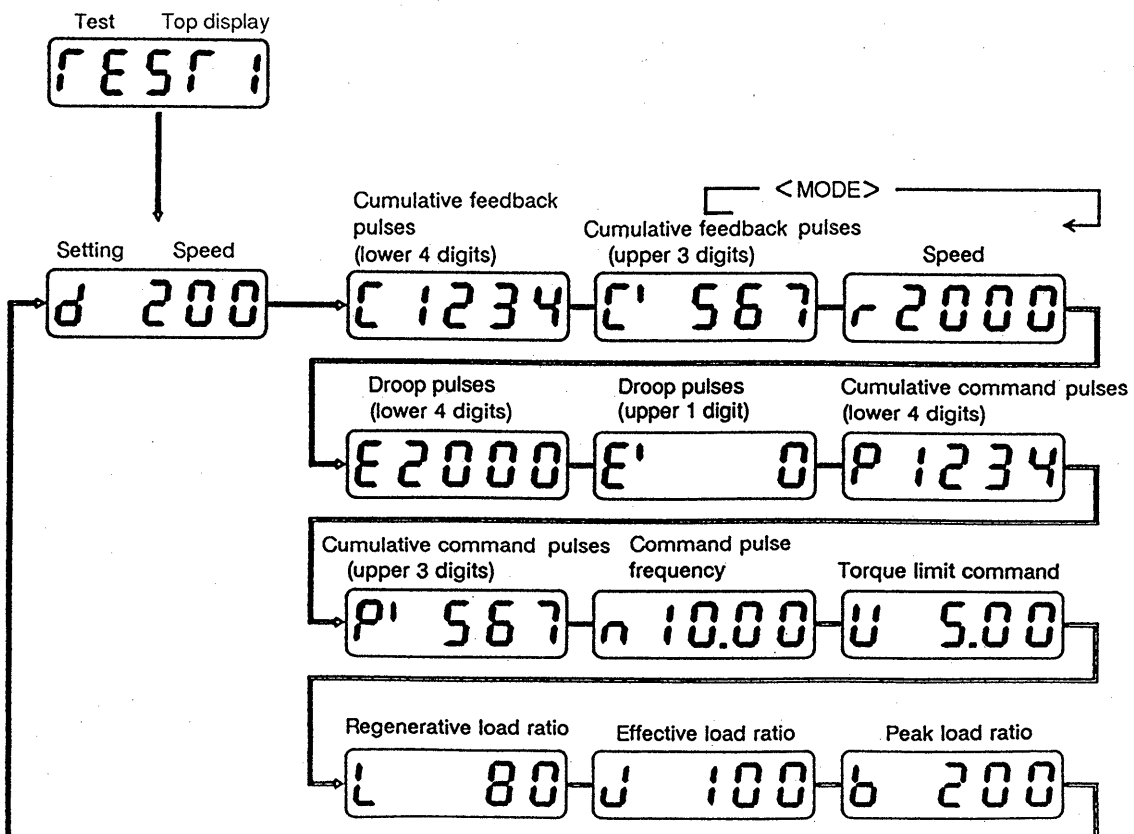

5. Adjustments and Application Operations

5-2.5 Alarm history clear (H2 display)

This mode is used to display and clear fault alarms that have occurred. The last four alarm codes are saved. Use the following procedure to clear the alarms.

(Operation procedure)

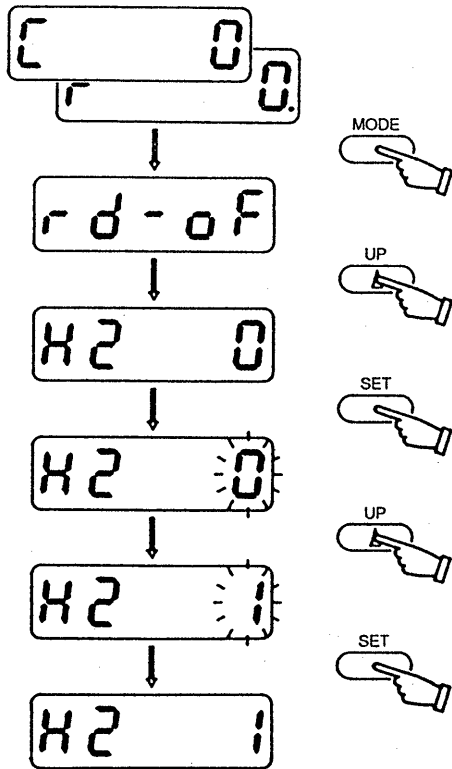

About 5 seconds after the power is turned ON, the status will be displayed.

[] 0: Position servo

r []: Speed servo

- Select the alarm history clear mode "H2 0" with the "MODE and UP" keys.

- "0" flickers with the "SET" key.
- Press the "UP" key once to make "1" flicker.
- The alarm history will be cleared when the "SET" key is pressed.

(Note) Any data other than "1" set in this mode will be ignored.

5. Adjustments and Application Operations

5-2.6 Offset adjustment mode (speed servo)

In this mode, an offset voltage can automatically be adjusted to zero. When the servo motor is rotating slowly with an internal or external analog circuit offset voltage, the following procedure can be used to automatically adjust the offset voltage to zero.

(1) Operation procedure

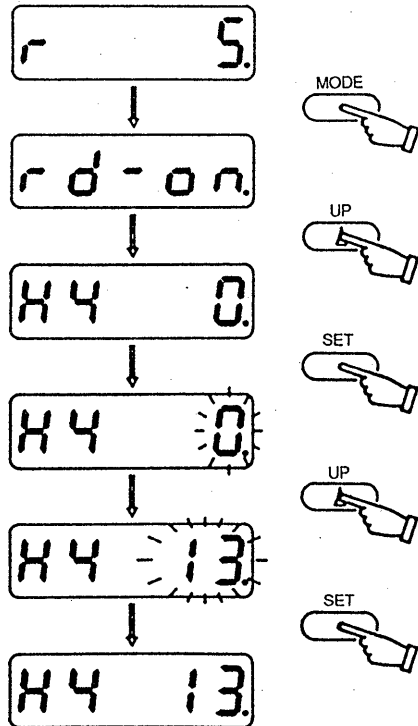

- Set the speed command (VC) input to zero (V).
- Select the analog speed command automatic offset adjustment display "H4 0" with the "MODE and UP" keys.
- "0" flickers with the "SET" key.
- Press the "UP" key to make "13" flicker.
- When the "SET" button is pressed, the automatic offset adjustment will be executed. (The parameter NO. 16 VC offset value will be automatically rewritten.)

(2) Precautions

- 1) Automatic offset adjustment cannot be executed when the speed command input voltage is $\pm 50\text{mV}$ or more at the servo amplifier's CN1 connector input pin.
- 2) Automatic offset adjustment can be operated in the servo ON state.
If automatic offset adjustment is executed when the SON signal and ST1 signal are ON and the servo motor is rotating slowly with the offset voltage, it can be confirmed that the motor will almost stop.

5-2.7 Check of the digital input/output signal (external input/output signal) mode

The ON-OFF status of the external input/output signal is indicated.
The function of the input/output signals and power ON can be checked.

- (1) Refer to Section 3-5.3 for the details of the position control external input/output signals.
- (2) Refer to Section 4-5.3 for the details of the speed control external input/output signals.

6. Methods for Using the Auxiliary Equipment and Options

6-1 Regenerative option

The servo amplifier does not have a built-in regenerative feature. The following regenerative options are available.

For the selection of the regenerative option, refer to Section 10-2. In principle, the MR-J40□ and larger units require an external regenerative option(s). Note that when the load inertia is small on a horizontal shaft or when the maximum operating speed is low, for example, the regenerative option(s) may not be required. Refer to Section 9-4 and select the regenerative option(s).

• Application chart

Servo amplifier	Regenerative option specifications			
	Model	Qty	Resistor	Regenerative power (W)
MR-J10A to 100A MR-J10A1 to 40A1 MR-J10MA to 70MA MR-J10MA1 to 40MA1	MR-RB013	1	52Ω	10
	MR-RB033	1	52Ω	30
	MR-RB064	2	52Ω	100 (2 pcs. connected in series)
MR-J200A	MR-RB064	1	26Ω	60
	MR-RB10	2	26Ω	150 (2 pcs. connected in series)
	MR-RB30	2	26Ω	500 (2 pcs. connected in series)
MR-J350A	MR-RB10	1	13Ω	100
	MR-RB30	1	13Ω	300
	MR-RB50	1	13Ω	500

Model: MR-RB013, 033, 064, 10

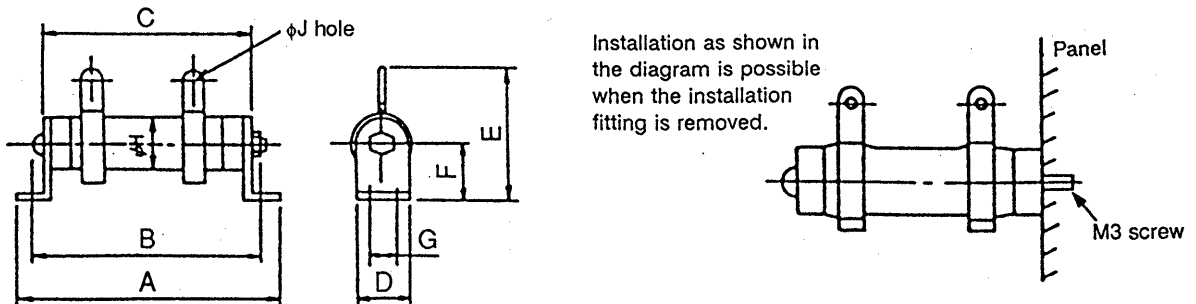

• Application chart

Regenerative option	Outer dimensions [mm]									
	A	B	C	D	E	F	G	H	J	
MR-RB013	110	101	85	18	35	16	4.5	18	3.2	
MR-RB033	192	173	152	26	54	22	6	26	3.2	
MR-RB064	306	287	266	26	54	22	6	26	4.3	
MR-RB10	335	309	274	40	78	40	9.5	40	5.5	
MR-RB30	The outer dimensions are shown in the page before.									
MR-RB50										

6. Methods for Using the Auxiliary Equipment and Options

MR-RB30(300W) Weight: 2.9kg

MR-RB50(500W) Weight: 5.6kg

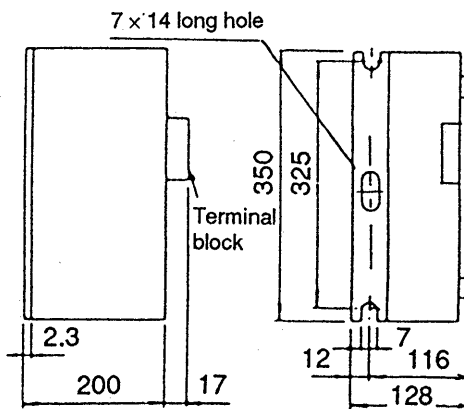
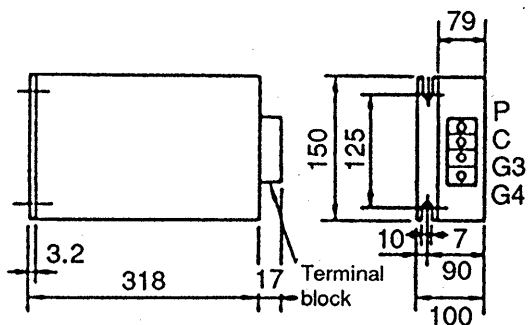

Note: Forcibly cool the unit with a cooling fan
(air flow 1.0m³/min or more, 92mm □ fan or more)

• Designation of the regenerative option

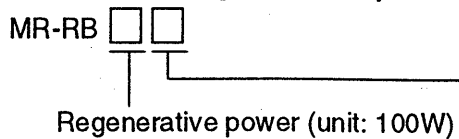

Resistance

Symbol	Resistance (Ω)
0	13
1	6.67
2	40
3	52
4	26

6. Methods for Using the Auxiliary Equipment and Options

• Connection of the regenerative unit

Use the following connection when the regenerative frequency is high and the regenerative option is used.

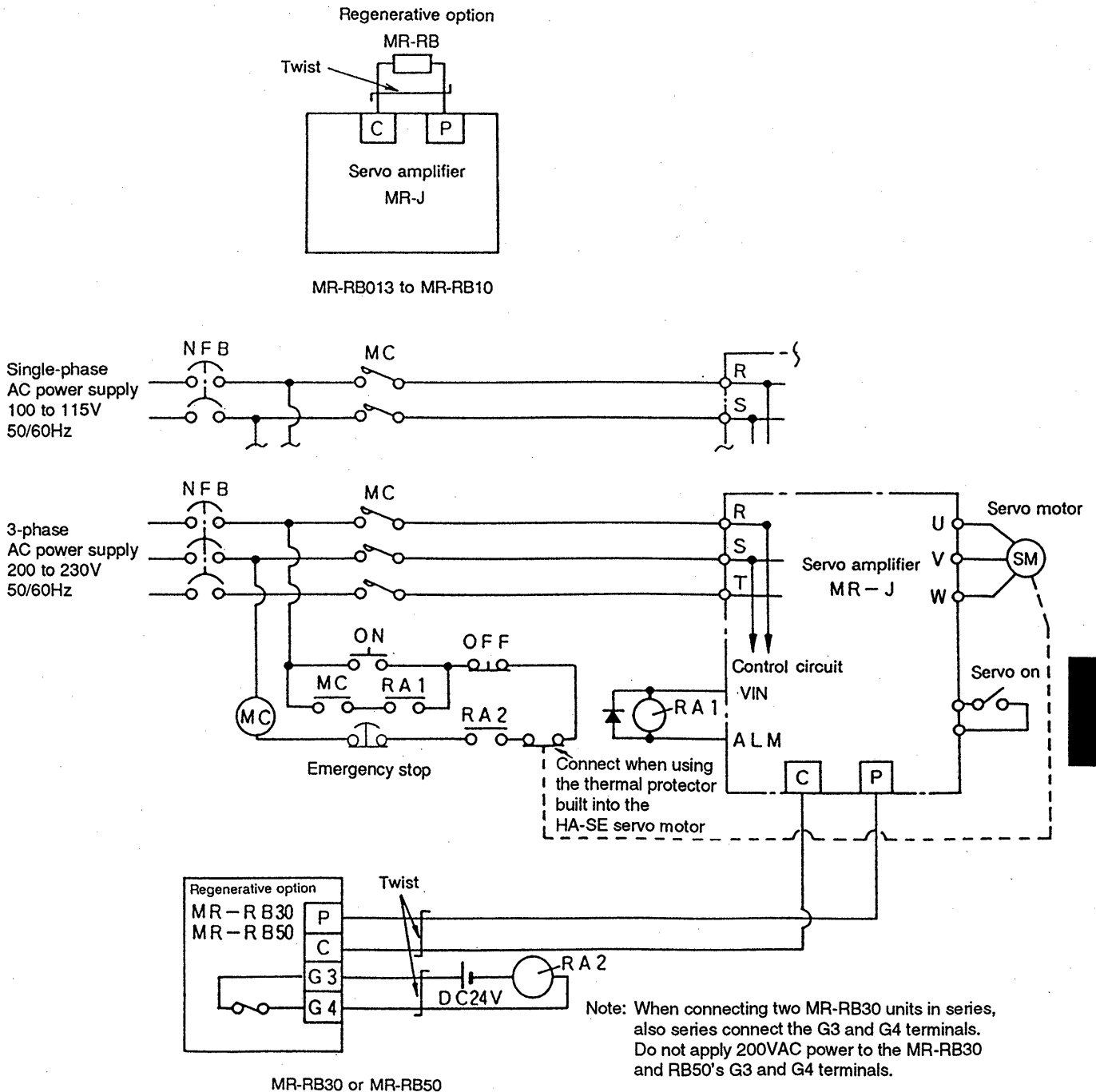

Precautions for use

1. Always twist the regenerative unit wires, and use the shortest wiring possible (5m or less).
2. Do not directly install the regenerative unit onto non-heatproof wall as the unit temperature rises to approximately 150°C. Use heat resistant wiring or use out heat resistant silicone tubes, etc. on the wires, and route the wires so that they do not contact the regenerative unit.

6. Methods for Using the Auxiliary Equipment and Options

6-2 Dynamic brake option

The dynamic brake option is used to quickly stop the servo motor without coasting during a power failure or when the protective circuit (alarm) is activated. Select the correct unit from the table below. The dimensions are shown in the lower right diagrams.

(1) Dynamic brake model number

Servo amplifier	Model	Weight
MR-J10A to 60A MR-J10A1 to 40A1 MR-J10MA to 40MA MR-J10MA1 to 40MA1	MR-SDBU-1C	0.8kg
MR-J70A, 70MA MR-J100A	MR-SDBU-1A	1.0kg
MR-J150A MR-J200A MR-J350A	MR-SDBU-2A	2.0kg

(2) Dynamic brake unit

Use this to suddenly stop the servo motor without coasting during a power failure or when the protective circuit is activated.

External dimension diagram

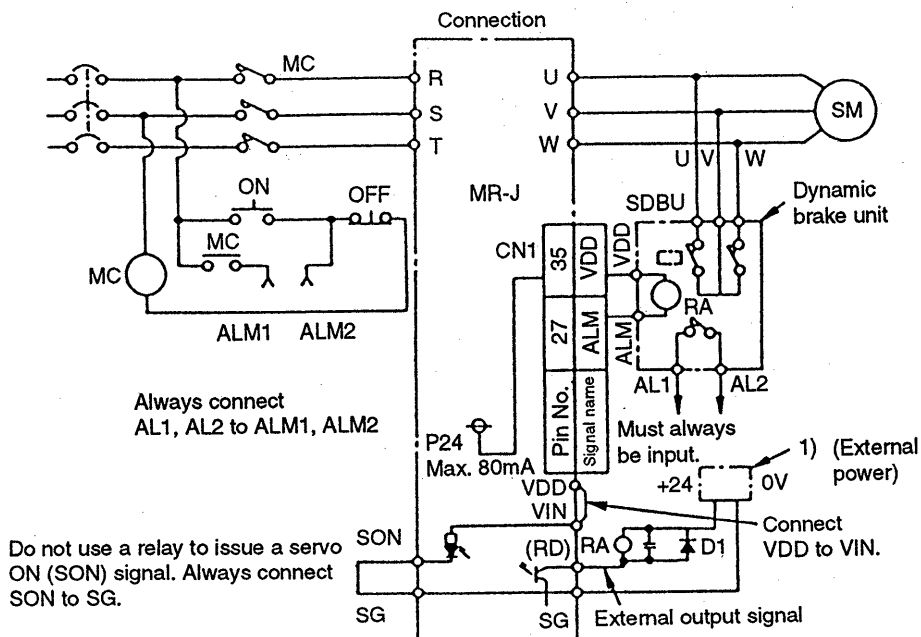
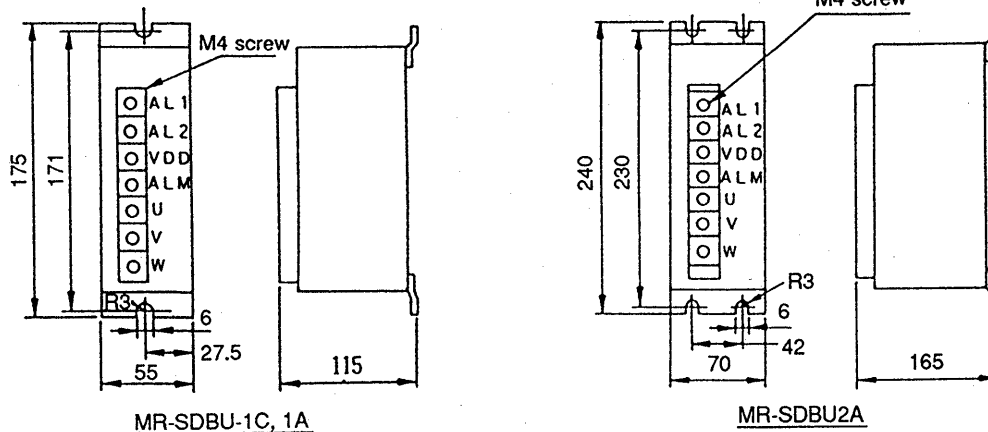

6. Methods for Using the Auxiliary Equipment and Options

- Note:
1. The ALM signal is used for the dynamic brake. Use AL1 and AL2 on the dynamic brake unit for the trouble signal.
 2. The AL1-AL2 will open during power off, an alarm or emergency stop. The operation will be approximately 10msec later than the CN1 pin 27 ALM signal.
 3. The brake unit is rated for short-time use. Do not use it frequently.
 4. Use of the MR-J power during dynamic brake use.
 - (1) Always use the internal VDD power for the dynamic brake.
 - (2) Always use the external power 1) for the output signals (RD, PF, etc.).
 5. To hold the motor shaft in lifting applications when servo is OFF, use a magnetic brake, etc. (The dynamic brake cannot hold the servo motor shaft.)
 6. To quickly stop the servo motor in emergency, use a sequence, in addition to the circuit shown above, to zero the speed command or position command.

(3) Timing chart during dynamic brake use

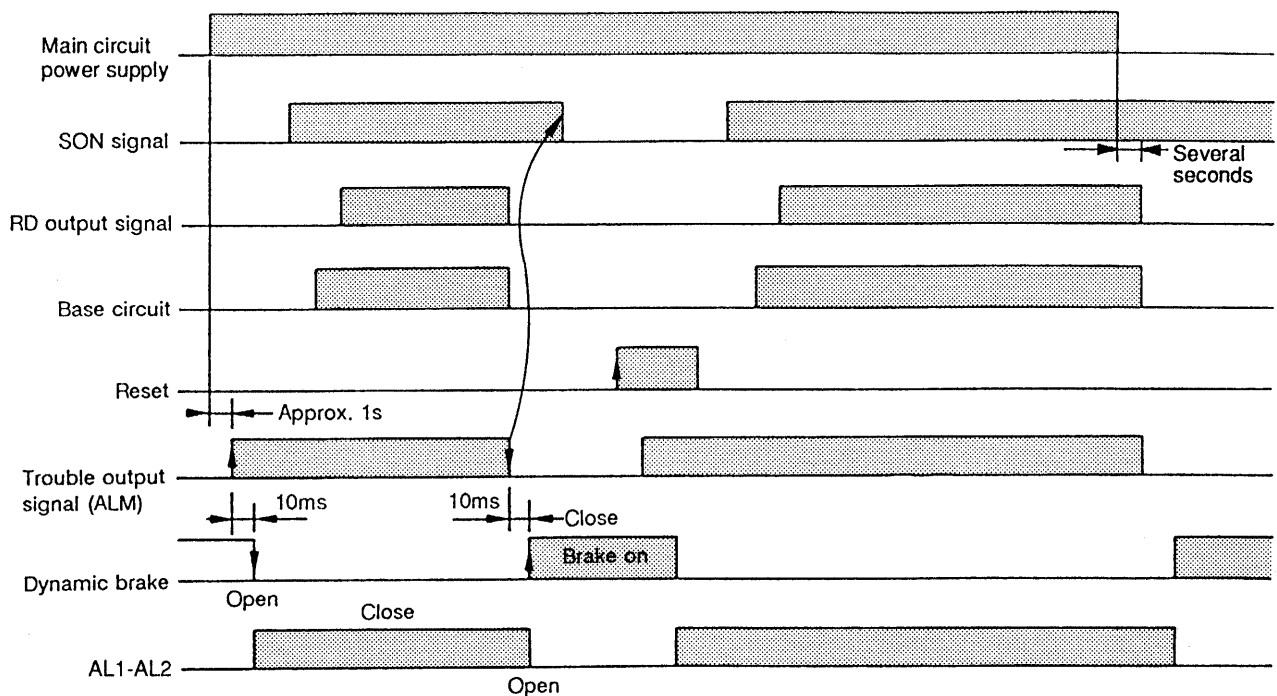

6. Methods for Using the Auxiliary Equipment and Options

6-3 Power factor improvement reactor FR-BAL

Use a reactor to improve the power factor and to suppress the in-rush current when the servo amplifier connected directly to a power transformer (500kVA or more, with wiring length of 10m or less).

Outer dimensions

Connection

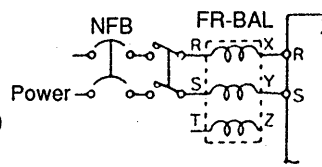
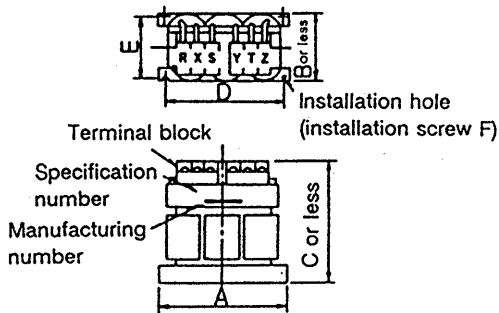

Single phase 100 V

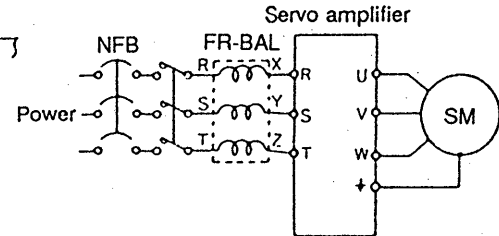

3-phase 200 V

Unit: mm

Model	Dimensions						Weight (kg)
	A	B	C	D	E	F	
FR-BAL-0.4K	135	64	120	120	45	M4	2
FR-BAL-0.75K	135	74	120	120	57	M4	2
FR-BAL-1.5K	160	76	145	145	55	M4	4
FR-BAL-2.2K	160	96	145	145	75	M4	6
FR-BAL-3.7K	220	95	200	200	70	M5	8.5
FR-BAL-7.5K	220	125	205	200	100	M5	14.5

6. Methods for Using the Auxiliary Equipment and Options

6-4 Cables and connectors

6-4.1 Option list

		Model	Product	Details	
Use one of these for CN2	1)	MR-JMCBL □ M	Encoder cable for HA-ME (-UL)/FE-UL series motor (50W to 750W)	Servo Amplifier side connector PCR-S20FS, PCR-LS20LA1 (Honda Tsushin Kogyo Co., Ltd.)	Relay connector PCR-E20PMRS-SL, PCR-S20PLMA2 Servo Motor encoder
	2)	MR-JCBL □ M	Encoder cable for HA-FE series motor (50W to 600W)	Servo Amplifier side connector (CN2) PCR-S20FS, PCR-LS20LA1 (Honda Tsushin Kogyo Co., Ltd.)	Relay connector MR-20RF, MR-20LK2 Servo Motor encoder
	3)	MR-JSCBL □ M	Encoder cable for HA-SE (-UL) series motor (500W to 3500W)	Servo Amplifier side connector (CN2) PCR-S20FS, PCR-LS20LA1 (Honda Tsushin Kogyo Co., Ltd.)	Encoder side connector MS3106B20-29S, MS3057-12A
	4)	MR-HCNS	Encoder connector set for HA-ME(-UL)/FE-UL series motor	Servo Amplifier side connector (CN2) PCR-S20FS: connector PCR-LS20LA1: case (Honda Tsushin Kogyo CO., Ltd.)	Relay connector PCR-E20PMRS-SL: connector PCR-S20PLMA2: case (Honda Tsushin Kogyo CO., Ltd.)
	5)	MR-JCNS	Encoder connector set for HA-FE series motor	Servo Amplifier side connector (CN2) PCR-S20FS: connector PCR-LS20LA1: case (Honda Tsushin Kogyo CO., Ltd.)	Relay connector MR-20RF: connector MR-20LK2: case (Honda Tsushin Kogyo CO., Ltd.)
	6)	MR-JSCNS	Encoder connector set for HA-SE (-UL) series motor	Servo Amplifier side connector (CN2) PCR-S20FS: connector PCR-LS20LA1: case (Honda Tsushin Kogyo CO., Ltd.)	Encoder side connector MS3106B20-29S, MS3057-12A
Use either for CN1	7)	MR-JCN1	CN1 connector	Servo Amplifier side connector (CN1) PCR-S36FS: connector PCR-LS36LA: case (Honda Tsushin Kogyo CO., Ltd.)	
	8)	MR-JTBL05M	Cable for CN1 relay terminal block	Servo Amplifier side connector (CN1) PCR-S36FS, PCR-LS36LA	Relay terminal block side connector FCN-367J040-AU/F
	9)	A6TBXY36	CN1 relay terminal block		

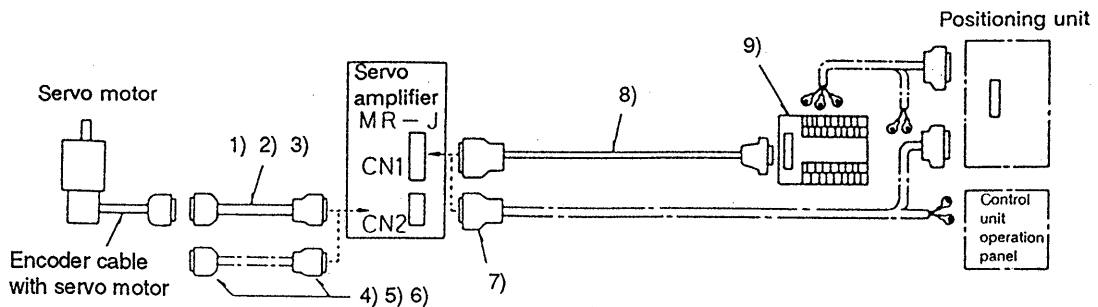

6. Methods for Using the Auxiliary Equipment and Options

6-4.2 Connector diagrams

Use the following for the signal line connectors.

(Unit: mm)

Servo amplifier Connector for CN1 (Made by Honda)

• Case appearance

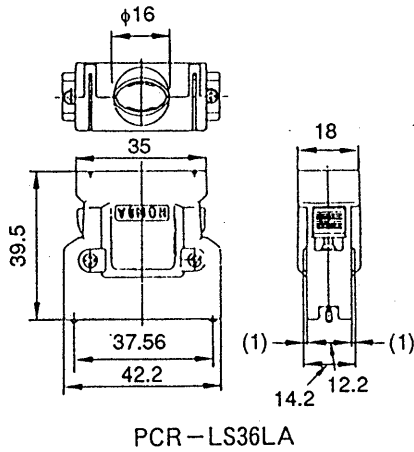

PCR-LS36LA

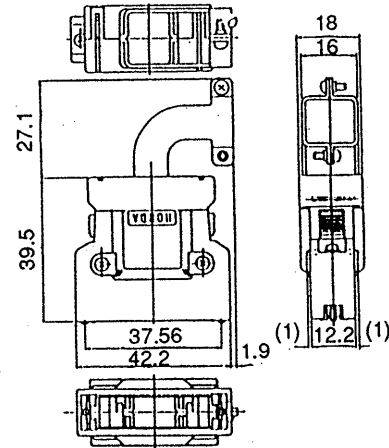

PCR-LS36LAW

No. of pins	Model	
	Connector	Case
36	PCR-S36FS (solder connection type)	PCR-LS36LA PCR-LS36LAW (Note)
	PCR-S36F (insulation displacement termination type) (Note)	

Insulation displacement termination tool: FHAT-0002A

Note: Not available from Mitsubishi.

Servo amplifier Connector for CN2 (Made by Honda)

• Case appearance

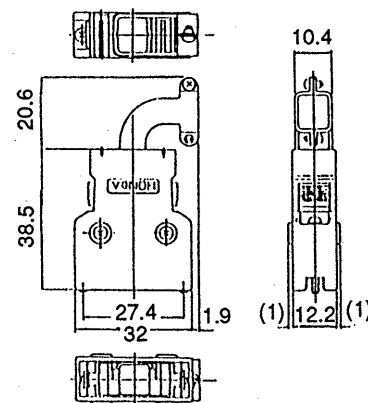
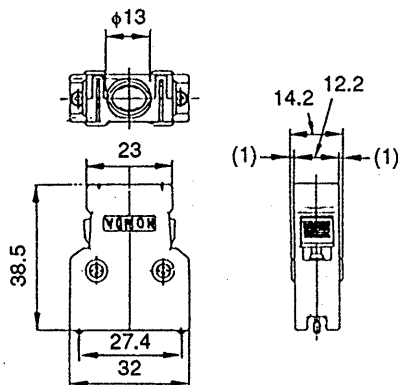

No. of pins	Model	
	Connector	Case
20	PCR-S20FS (solder connection type)	PCR-LS20LA1 PCR-LS20LA1W (Note)
	PCR-S20F (insulation displacement termination type) (Note)	

Insulation displacement termination tool: FHAT-0002A

Note: Not available from Mitsubishi.

6. Methods for Using the Auxiliary Equipment and Options

(Unit: mm)

Connector for encoder (Made by Honda) Applicable to HA-ME (-UL)/FE-UL motors

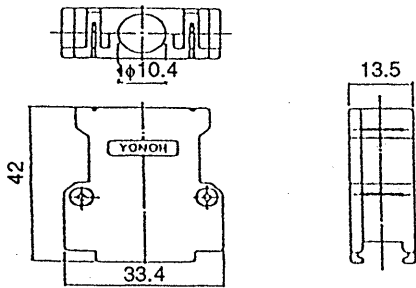

No. of pins	Model	
	Connector	Case
20	PCR-E20PMRS-SL (solder connection type)	PCR-S20PMLA2

Connector for encoder (Made by Honda) Applicable to HA-FE motors

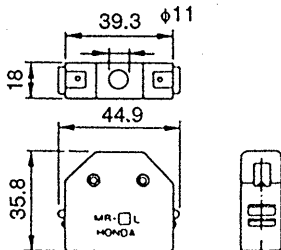

No. of pins	Model	
	Connector	Case
20	MR-20RF	MR-20LK2

Connector for encoder (Made by DDK, Ltd., Japan Aviation Electronics) Applicable to HA-SE(-UL) motor

Straight plug MS3106B20-29S

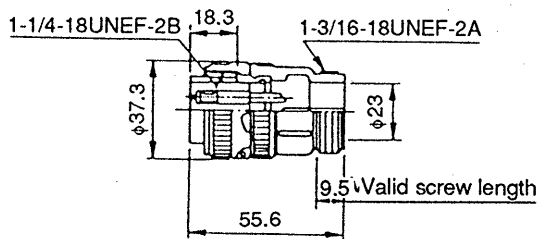

Angle plug MS3108B20-29S

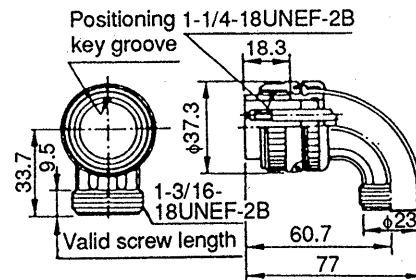

Cable clamp MS3507-12A

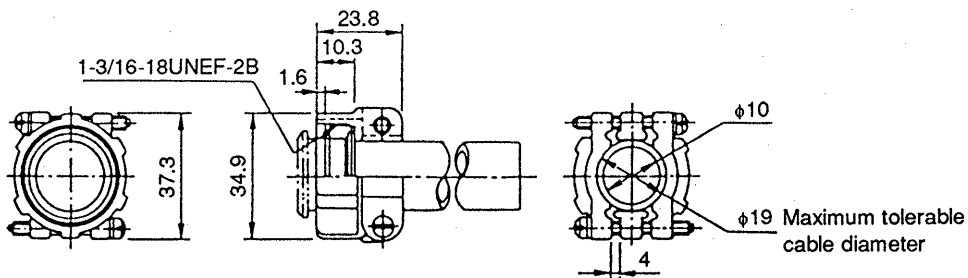

6

6. Methods for Using the Auxiliary Equipment and Options

6-4.3 Cable specifications

Use the following or equivalent twisted pair shielded wires for the motor encoder and control signal connections. If the wiring between the motor and amplifier is long and the servo motor is required to move, use the cables which have the flexibility resistance characteristics as below.

- 1) Multi-core shielded wire for detector (total-shielded wire)

Core number size (mm)	Finish diameter (mm)	Characteristics of one wire	
		Components (no./mm)	Conductive resistivity (Ω /km)
12 pairs \times 0.2	11.0	40/0.08	100.5

- 2) Two-core shielded wire

Core number size (mm)	Finish diameter (mm)	Characteristics of one wire	
		Components (no./mm)	Conductive resistivity (Ω /km)
2 \times 0.3	4.18	19/0.16	54.8 \times 2

6. Methods for Using the Auxiliary Equipment and Options

(2) MR-JCBL□M

MR-JCBL5M
(5m)

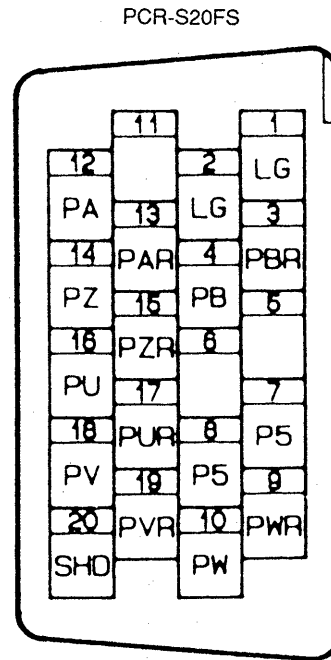
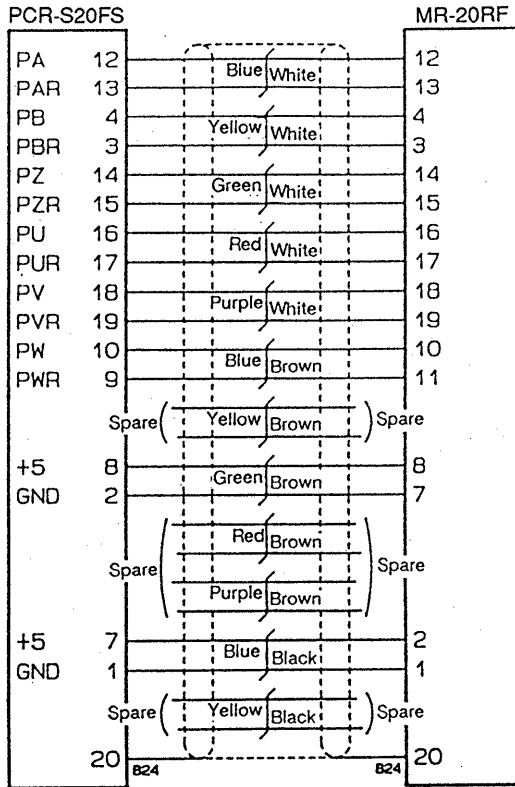

MR-JCBL10M to
MR-JCBL30M
(10 to 30m)

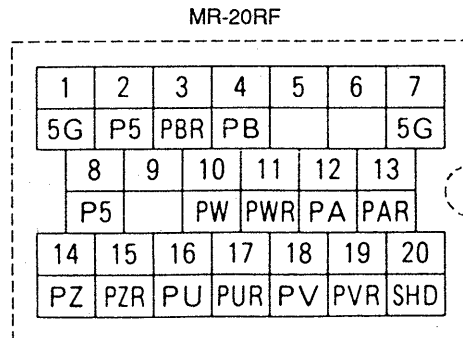
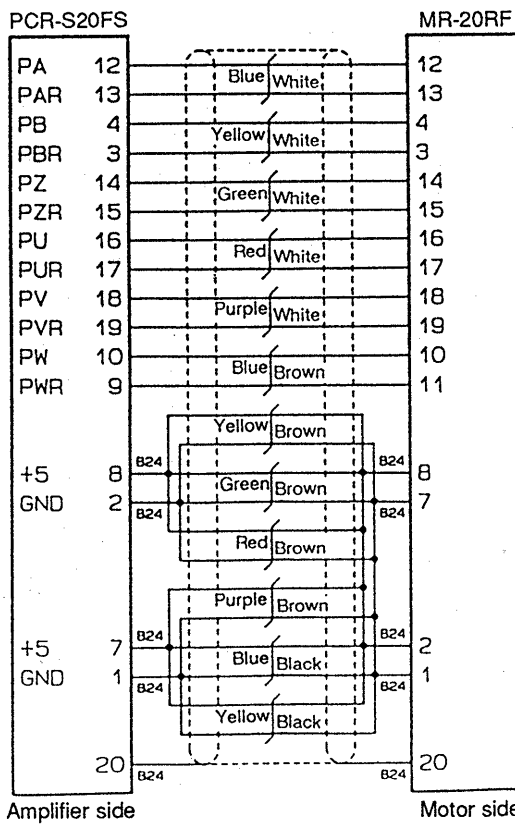

Layout diagram looking
from wiring side

Connector pin layout
diagram for encoder
signal connectors

6. Methods for Using the Auxiliary Equipment and Options

(3) MR-JSCBL□M

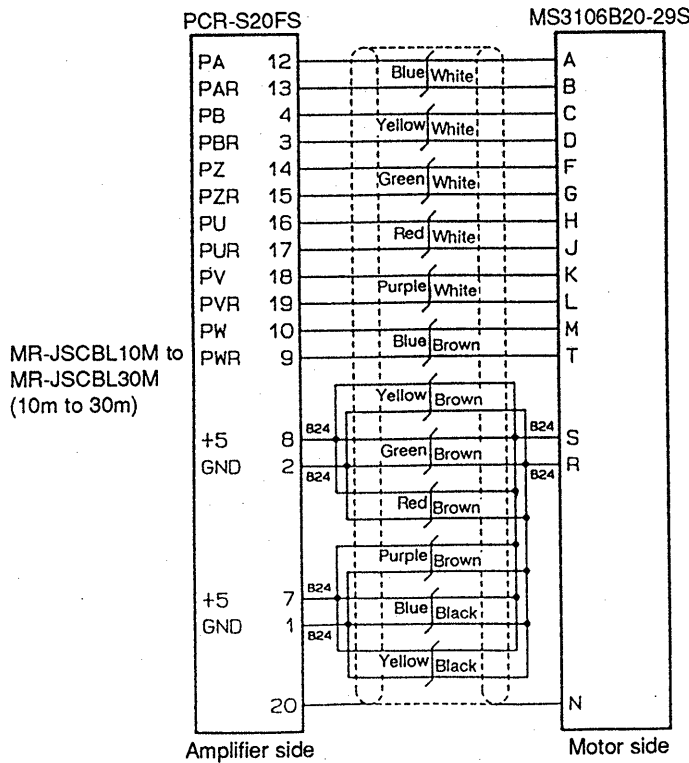
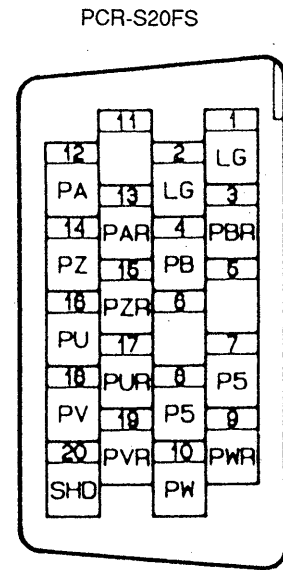
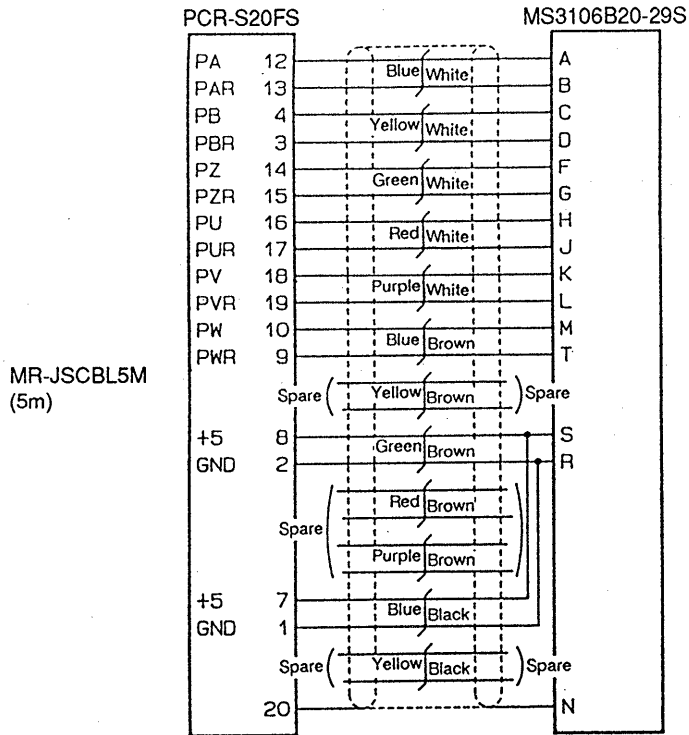

MS-3106B20-29S

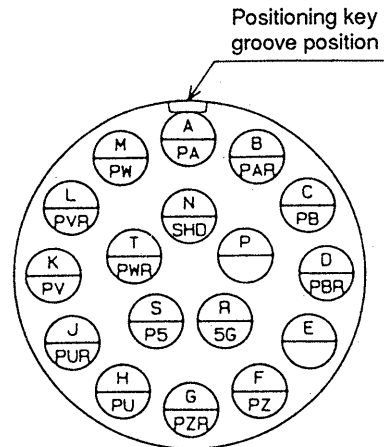

6. Methods for Using the Auxiliary Equipment and Options

6-5 Junction terminal block (Model: A6TBXY36)

(1) Outer dimensions(mm)

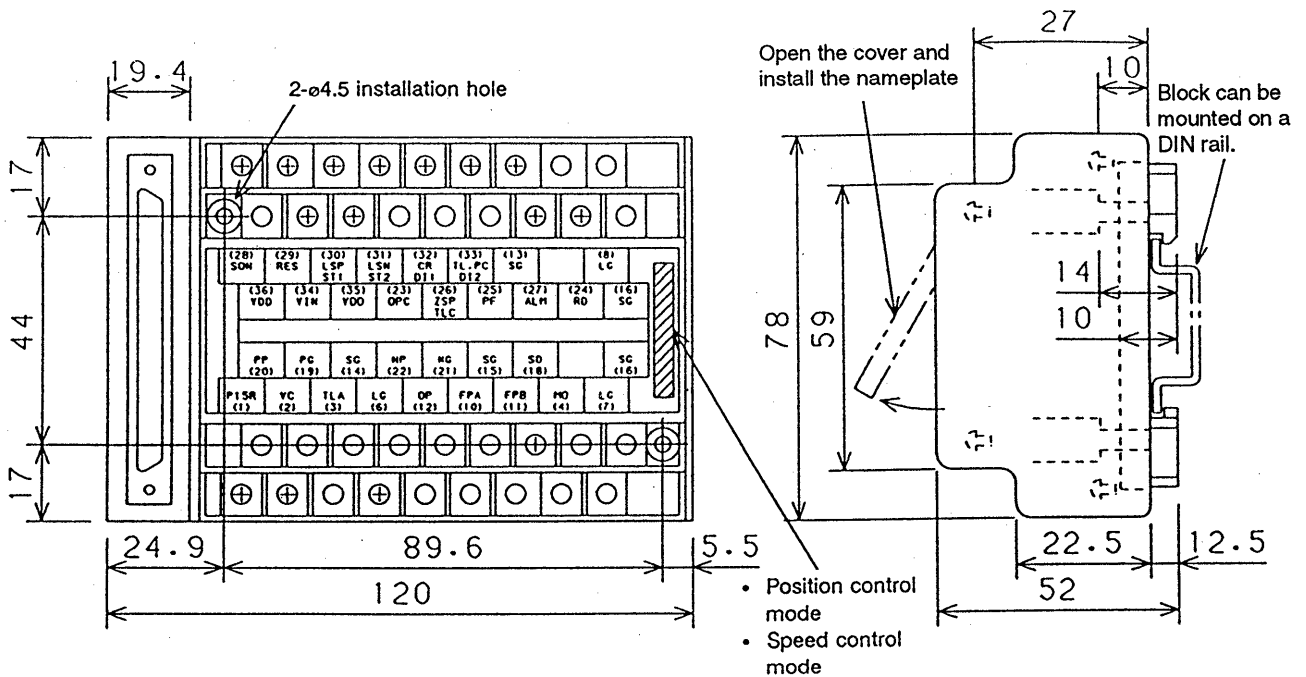

(2) Instruction for using the junction terminal block with MR-JTBL cable together

- Note 1. When connecting the junction terminal block (A6TBXY36) with the MR-JTBL□M cable, the terminal symbols will be different, use the correct enclosed nameplate.
2. The "*" marked terminals on the terminal symbol name plate 1) and 2) (next page) are connected internally, do not connect them or use them for junction terminals.
3. For the "()" marked terminals on the terminal symbol nameplate, enter the corresponding signal designation as selected in parameter 19.

6. Methods for Using the Auxiliary Equipment and Options

3) Detailed diagram of AERSBAN-ESET (Cable clamp/earth plate) installation

When installing AERSBAN-ESET (cable clamp/earth plate), peel part of the cable cover, and expose the outer shield.

Insert the exposed part into the cable clamp on the earth plate, and tighten clamp.

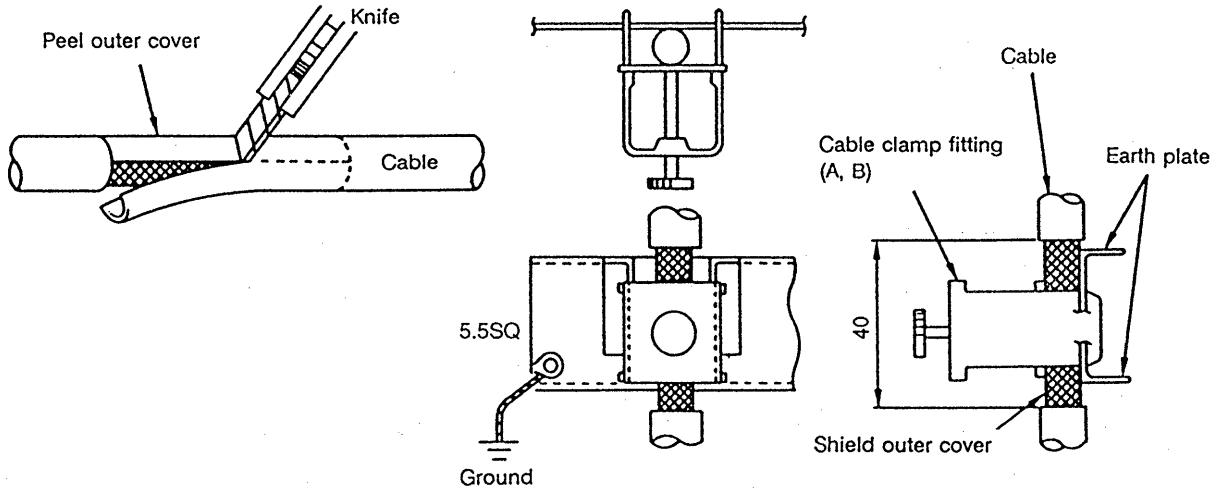

6. Methods for Using the Auxiliary Equipment and Options

6-6 Electrical wires, breakers and magnetic contactors

Select the electrical wires for the main circuit, breakers and magnetic contactor according to the following chart.

- Select the No-Fused Breaker (NFB) while taking the power capacity and wire size into consideration.
- Install a magnetic contactor (MC), that meets the power capacity and wiring length into the AC input power supply, so that the power will be switched off when an alarm occurs.
- The wire (core) size is for wire length 30m or less.
- When connecting directly to a large capacity power transformer (500kVA or more, with wiring 10m or less), an excessive current will flow when the power is switched on, and may damage the converter section. Install a reactor (FR-BAL) (option) to suppress the current.

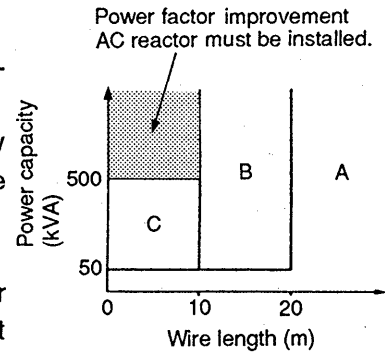

Servo amplifier	No-fuse breaker (NFB)	Fuse		
		Type (Manufacturer)	Class	Amp.
MR-J10A, 20A, 10A1	NF30 type 5A	NON-10 (Buss) or OT10 (Gould)	K5	10
MR-J10MA, 20MA, 10MA1	NF30 type 5A	NON-10 (Buss) or OT10 (Gould)		10
MR-J40A, 40MA	NF30 type 10A	NON-15 (Buss) or OT15 (Gould)		15
MR-J60A	NF30 type 15A	NON-20 (Buss) or OT20 (Gould)		20
MR-J70A, 70MA	NF30 type 15A	NON-20 (Buss) or OT20 (Gould)		20
MR-J100A	NF30 type 15A	NON-25 (Buss) or OT25 (Gould)		25
MR-J200A	NF30 type 20A	NON-40 (Buss) or OT40 (Gould)		40
MR-J350A	NF30 type 30A	NON-70 (Buss) or OT70 (Gould)		70
MR-J20A1, 20MA1	NF30 type 10A	NON-10 (Buss) or OT10 (Gould)		10
MR-J40A1, 40MA1	NF30 type 15A	NON-10 (Buss) or OT10 (Gould)		10

Servo amplifier	Magnetic contactor (MC)			Wire size (mm ²)			Reactor FR-BAL
	A	B	C	Terminals R,S,T	Terminals U,V,W	Terminals P,C	
MR-J10A, 20A, 10A1	S-K18	S-K21	S-K21	2	2	2	FR-BAL-0.4K
MR-J10MA, 20MA, 10MA1	S-K18	S-K21	S-K21	2	2	2	FR-BAL-0.4K
MR-J40A, 40MA	S-K18	S-K21	S-K21	2	2	2	FR-BAL-0.75K
MR-J60A	S-K18	S-K21	S-K21	2	2	2	FR-BAL-1.5K
MR-J70A, 70MA	S-K21	S-K25	S-K50	2	2	2	FR-BAL-1.5K
MR-J100A	S-K21	S-K25	S-K50	2	2	2	FR-BAL-2.2K
MR-J200A	S-K18	S-K18	S-K18	3.5	3.5	2	FR-BAL-3.7K
MR-J350A	S-K20	S-K20	S-K20	5.5	5.5	2	FR-BAL-7.5K
MR-J20A1, 20MA1	S-K18	S-K21	S-K21	2	2	2	FR-BAL-0.75K
MR-J40A1, 40MA1	S-K18	S-K21	S-K21	2	2	2	FR-BAL-1.5K

6-7 Selection of relays

Relay used especially for switching analog input command and digital input command (interface DI-1)	Protect defective contacts with a small current signal (twin contacts). (Ex.) OMRON: type G2A, MY
Relay used for digital output signals (interface DO-1)	Small relay with 12VDC, 24VDC or 24VDC of 40mA or less (Ex.) OMRON: type MY

6. Methods for Using the Auxiliary Equipment and Options

6-8 Selection of the external speed command and external torque limit command potentiometers (pof)

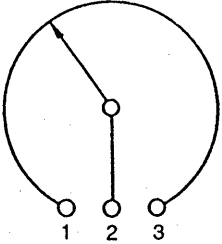
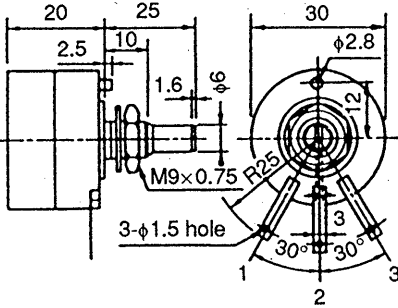
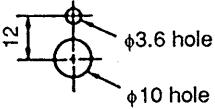
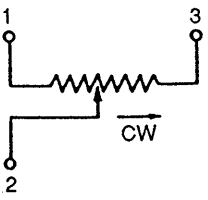
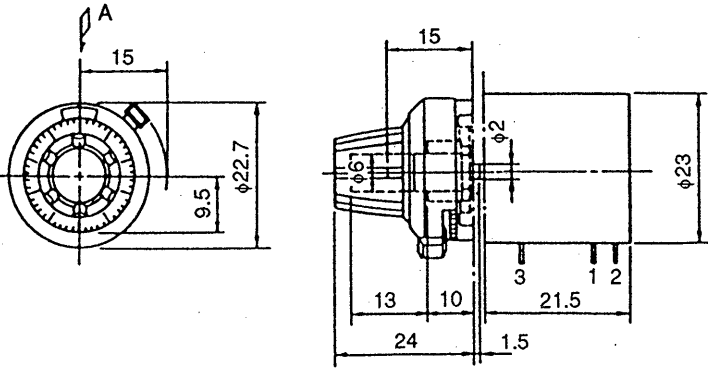
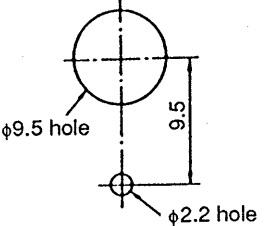
Single-rotation type	<p>Model WA2WYA2SEBK2KΩ Wire-wound variable resistor 2W2kΩ B characteristics Shaft rotation angle 300° \pm 5°</p> <p>Note: Maker (Japan Resistor Manufacture Co., Ltd.) standard WA2W can be used.</p>	<p>Connection diagram</p> 														
	<p>External dimension diagram [Unit: mm]</p> 	<p>Detailed diagram of panel holes [Unit: mm]</p> 														
<table border="1"> <thead> <tr> <th>Rated Power</th> <th>Resistance</th> <th>Resistance Tolerance</th> <th>Dielectric Strength (for 1 minute)</th> <th>Insulation Resistance</th> <th>Mechanical Rotary Angle</th> <th>Rotary Torque</th> </tr> </thead> <tbody> <tr> <td>2W</td> <td>2kΩ</td> <td>\pm10%</td> <td>700V A.C.</td> <td>100MΩ or more</td> <td>300° \pm5°</td> <td>10 to 100g-cm or less</td> </tr> </tbody> </table>			Rated Power	Resistance	Resistance Tolerance	Dielectric Strength (for 1 minute)	Insulation Resistance	Mechanical Rotary Angle	Rotary Torque	2W	2k Ω	\pm 10%	700V A.C.	100M Ω or more	300° \pm 5°	10 to 100g-cm or less
Rated Power	Resistance	Resistance Tolerance	Dielectric Strength (for 1 minute)	Insulation Resistance	Mechanical Rotary Angle	Rotary Torque										
2W	2k Ω	\pm 10%	700V A.C.	100M Ω or more	300° \pm 5°	10 to 100g-cm or less										
Multi-rotation type	<p>Model Helical pot RRS10 (M) 2kΩ Multi-dial 23M (10 revolutions) Japan Resistor Manufacture Co., Ltd.</p>	<p>Connection diagram</p> 														
	<p>View A</p> 	<p>Detailed diagram of panel holes [Unit: mm] Panel thickness: 2 to 6mm</p> 														
<table border="1"> <thead> <tr> <th>Rated Power</th> <th>Resistance</th> <th>Resistance Tolerance</th> <th>Dielectric Strength (for 1 minute)</th> <th>Insulation Resistance</th> <th>Mechanical Rotary Angle</th> <th>Rotary Torque</th> </tr> </thead> <tbody> <tr> <td>1W</td> <td>2kΩ</td> <td>\pm5%</td> <td>750V A.C.</td> <td>1,000MΩ or more</td> <td>3600° +10° -0°</td> <td>100g-cm or less</td> </tr> </tbody> </table>			Rated Power	Resistance	Resistance Tolerance	Dielectric Strength (for 1 minute)	Insulation Resistance	Mechanical Rotary Angle	Rotary Torque	1W	2k Ω	\pm 5%	750V A.C.	1,000M Ω or more	3600° +10° -0°	100g-cm or less
Rated Power	Resistance	Resistance Tolerance	Dielectric Strength (for 1 minute)	Insulation Resistance	Mechanical Rotary Angle	Rotary Torque										
1W	2k Ω	\pm 5%	750V A.C.	1,000M Ω or more	3600° +10° -0°	100g-cm or less										

6. Methods for Using the Auxiliary Equipment and Options

6-9 Noise reduction techniques

Noises are classified into external noises which enter the servo amplifier and cause it to malfunction and those radiated by the servo amplifier which cause peripheral devices to malfunction. The servo amplifier is designed to resist noises. However, since it is an electronic device which uses small signals, it requires general noise reduction as mentioned below. And, since the output of the servo amplifier is chopped by high carrier frequencies, the servo amplifier can be a source of noise. If peripheral devices malfunction due to noises produced by the servo amplifier, noise preventive measures must be provided. The measures will vary slightly according to the route of noise transmission.

1) General reduction techniques

- Avoid laying power lines (input and output cables) and signal cables side by side or bundling not bundle them together. Separate power lines from signal cables.
- Use shielded twisted-wire pair cables for connecting to a encoder and for control signal transmission, and connect the shield to the SD terminal.
- Ground the servo motor, servo amplifier, etc. together at one point (no loops).

2) Reduction techniques for external noises that cause the servo amplifier to malfunction

If there are noise sources (such as magnetic contactor, magnetic brake, and a large number of relays) which make a large amount of noise near the servo amplifier and the servo amplifier may malfunction, the following techniques are required.

- Provide surge absorbers on the noise sources to suppress noises.
- Attach data line filters to the signal cables.
- Ground the shields of the encoder connecting wire and the control signal cables with cable clamp fittings.

3) Techniques for noises radiated by the servo amplifier that cause peripheral devices malfunction

Noises which the servo amplifier produces are classified into those which are radiated from the cables connected to the servo amplifier body and the servo amplifier main circuits (input and output circuits), those which are induced electromagnetically or statically by the signal cables of the peripheral devices which are located close to the main circuit wires, and those which are transmitted through the power supply cables.

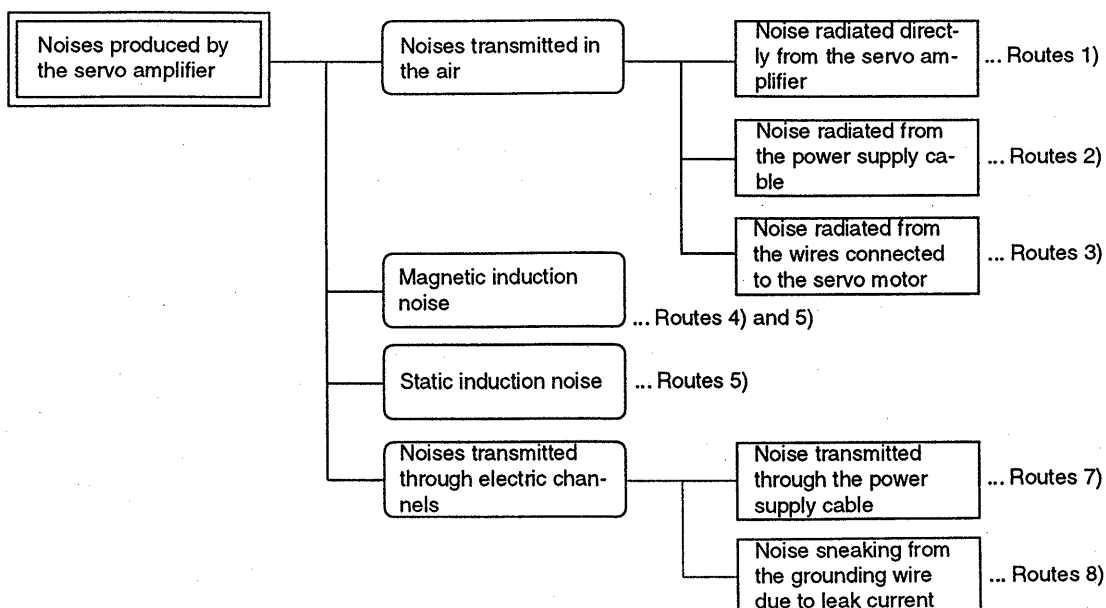

6. Methods for Using the Auxiliary Equipment and Options

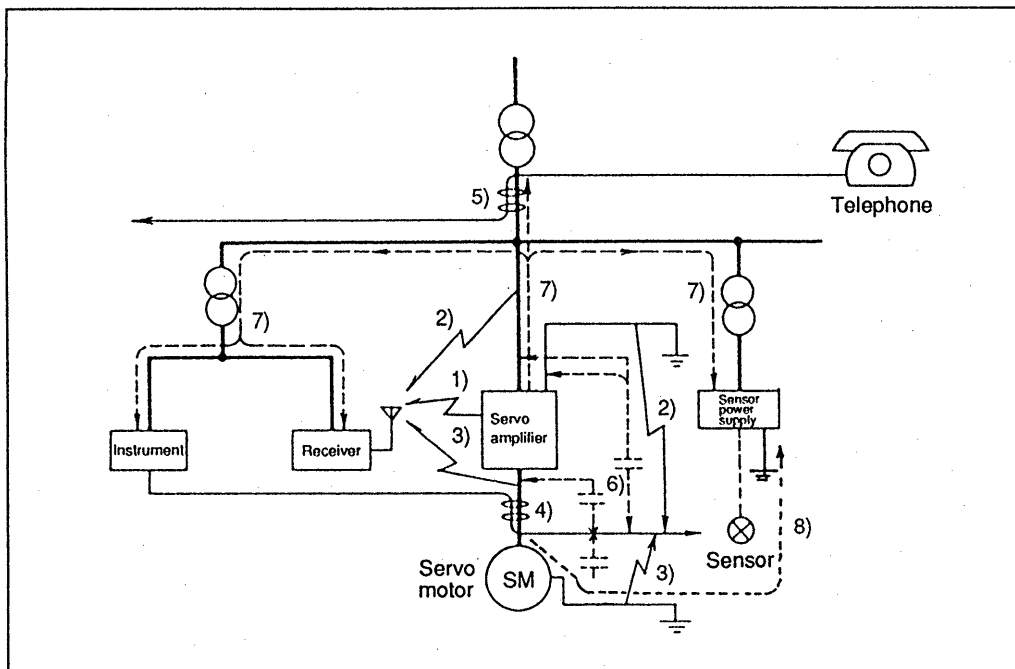

Noise transmission route	Countermeasures
1) 2) 3)	<p>When measuring instruments, receivers, sensors, etc. which handle weak signals and may malfunction due to noise and/or their signal cables are installed on a panel together with a servo amplifier or close to a servo amplifier, such devices may malfunction due to noise transmitted through the air. The following techniques are required.</p> <ol style="list-style-type: none"> (1) Provide maximum clearance between the devices which are liable to be influenced by noise and servo amplifier. (2) Provide maximum clearance between the signal cables which are liable to be influenced by noise and the I/O cables of the servo amplifier. (3) Avoid laying power lines (I/O cables of the servo amplifier) and signal cables side by side or bundling them together. (4) Insert a line noise filter on the I/O cables or a radio frequency noise filter on the input line. (5) Use shielded wires for the signal and power cables or put cables in separate metal conduits.
4) 5) 6)	<p>When the power lines and the signal cables are laid side by side or bundled together, magnetic induction noise and static induction noise may be transmitted through the signal cables and malfunction may occur. The following are required.</p> <ol style="list-style-type: none"> (1) Provide maximum clearance between the devices which are liable to be influenced by noise and servo amplifier. (2) Provide maximum clearance between the signal cables which are liable to be influenced by noise and the I/O cables of the servo amplifier. (3) Avoid laying power lines (I/O cables of the servo amplifier) and signal cables side by side or bundling them together. (4) Use shielded wires for signal and power cables or put the cables in separate metal conduits.
7)	<p>When the power supply of peripheral devices is connected to the power supply of the servo amplifier system, noises produced by the servo amplifier may be transmitted backward through the power supply cable and the devices may malfunction. The following techniques are required.</p> <ol style="list-style-type: none"> (1) Insert a radio frequency noise filter (FR-BIF) on the power cables (I/O cables) of the servo amplifier. (2) Insert a radio frequency noise filter (FR-BLF, FR-BSF01) on the power cables of the servo amplifier.
8)	<p>When the cables of peripheral devices are connected to the servo amplifier to make a closed loop circuit, leakage current will flow through the grounding wire of the servo amplifier to the peripheral devices and malfunction may occur. In that case, malfunction may be prevented by disconnecting the grounding wire of the peripheral device.</p>

6. Methods for Using the Auxiliary Equipment and Options

(1) Data line filter

Noise can be prevented by installing a data line filter onto the pulse output cable of the pulse train command unit (AD71, etc.) or the servo motor encoder cable. Use the following data line filter or equivalent.

Ex: Data line filter: ZCAT3035-1330 [Made by TDK]

ESD-SR-25 [Made by Tokin]

Note: Contact the manufacturer for details of dimensions and type names.

Impedance specifications (ZCAT3035-1330)

Impedance (Ω)	
10 to 100MHz	100 to 500MHz
80	150

Note: The above impedance value includes the impedance of the cable (measured value) and is not a guaranteed value.

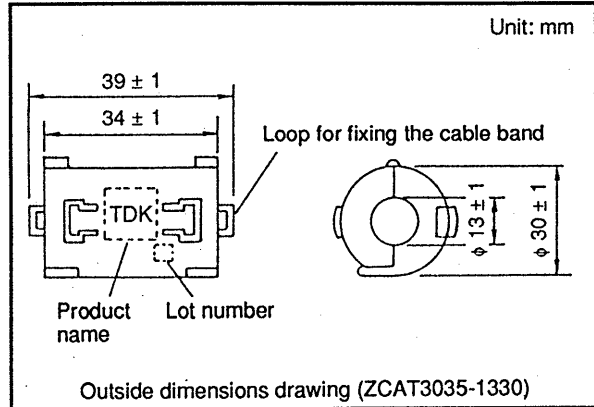

(2) Surge suppressor

The recommended surge suppressor for installation an AC relay, AC valve, AC magnetic brake or the like in the vicinity of the amplifier is shown below. Use this product or equivalent.

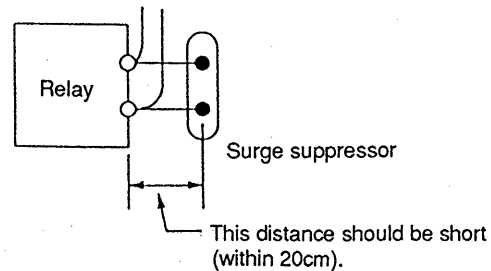
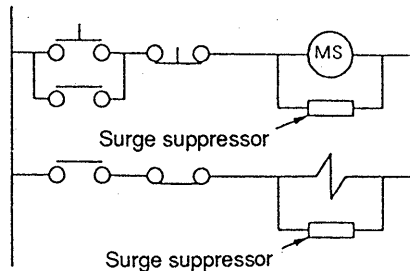

(Ex.) 972A-2003 504 11 (Made by Matsuo Electric Co., Ltd. — 200VAC rating)

Rated Current AC(V)	C(μ F)	R(Ω)	Test Voltage AC(V)
200	0.5	50(1W)	Across T-C 1000 (1 to 5s)

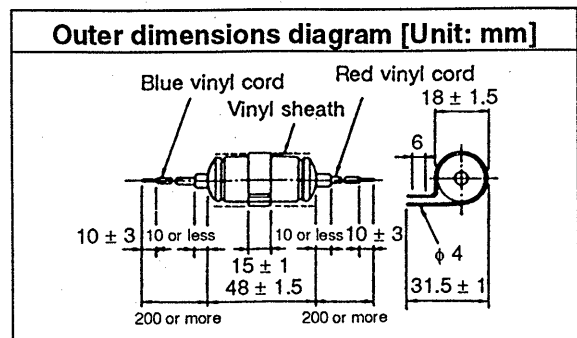

Maximum voltage: Not less than 4 times the drive voltage of the relay or the like

Maximum current: Not less than twice the drive voltage of the relay or the like

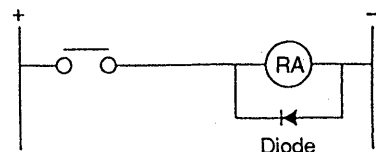

6. Methods for Using the Auxiliary Equipment and Options

(3) Cable clamp fitting (AERSBAN-□ SET)

The shield wire earth plate normally only needs to be connected to the connector's SD terminal. However, the effect can be increased by directly connecting the wire to an earth plate as shown below.

Install the earth plate near the servo amplifier for the encoder cable. Peel part of the cable sheath to expose the shield, and insert that part into the earth plate with the cable clamp. If the cable is thin, clamp several cables in a bunch.

Please contact Mitsubishi when the cable clamp is required. The clamp comes as a set with the earth plate.

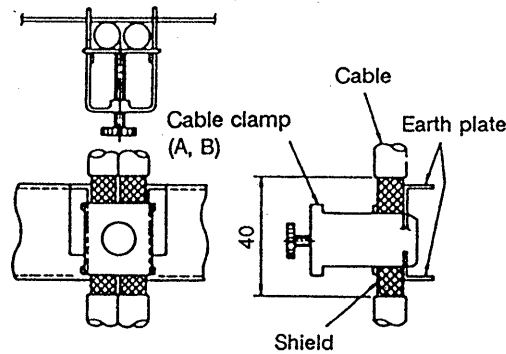

Clamp section diagram

• Outer dimensions diagram [Unit: mm]

Earth plate

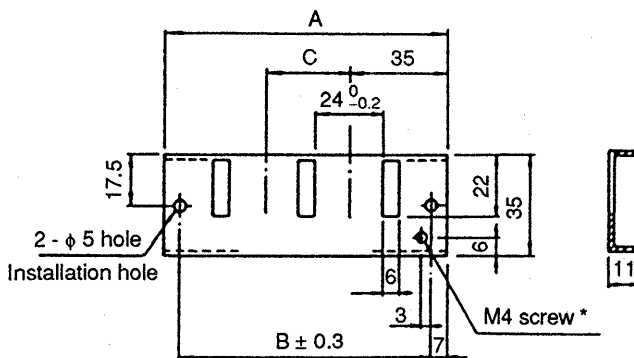

Cable clamp

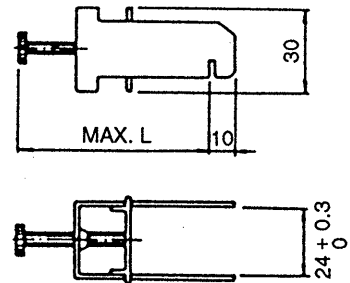

- 1) Always wire from the earth plate to the cabinet ground.
- 2) * Screw hole for wiring to cabinet ground.

	A	B	C	Enclosed fittings
AERSBAN-DSET	100	86	30	Fitting A: 2pcs.
AERSBAN-ESET	70	56	—	Fitting B: 1pc.

	L
Clamp A	70
Clamp B	45

6. Methods for Using the Auxiliary Equipment and Options

(4) Line noise filter (FR-BLF, FR-BSF01)

These filters are effective in suppressing noises radiated from the power supply side and the output side of the servo amplifier and also in suppressing high-frequency leakage current (zero-phase current) especially within 0.5MHz to 5MHz band.

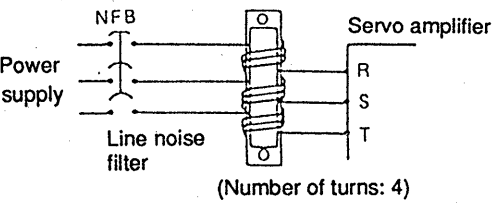
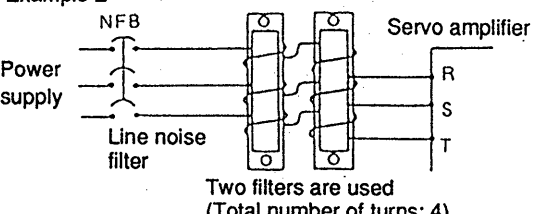
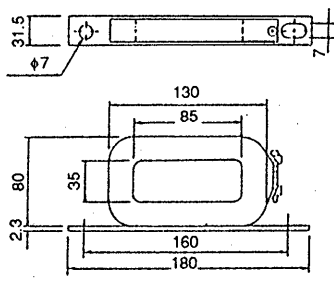
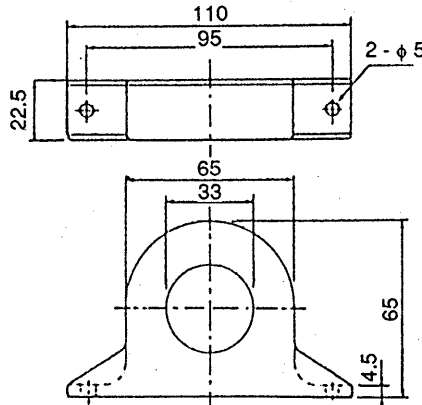
Connection chart	Outside dimensions drawing (Unit: mm)
<ul style="list-style-type: none"> Wind the wires connected to a three-phase power supply on equal number of times in the same direction, and insert the filter to the power supply side and the output side of the servo amplifier. The effect of the filter on the power supply side becomes higher as the number of winds becomes larger. The number of turns is generally four. On the output side, the number of turns must be four or less. <p>Note 1: Do not wind the grounding wire together with the three-phase power wires. The filter effect will decrease. Use caution when a four-core cable is used. Use a separate wire for grounding.</p> <p>Note 2: If the wires are too thick to be wound, use two filters or more and the number of turns should be as mentioned above.</p> <p>Example 1</p>  <p>(Number of turns: 4)</p> <p>Example 2</p>  <p>Two filters are used (Total number of turns: 4)</p>	<p>FR-BLF (for MR-J350□ and higher)</p>  <p>FR-BSF01 (for MR-J200□ and over)</p> 

(5) Radio noise filter (FR-BIF)...exclusively for the input side

This filter is effective in suppressing noises radiated from the power supply side of the servo amplifier especially in 10MHz and lower radio frequency band. Exclusively for the input side and applicable to all types of servo amplifiers.

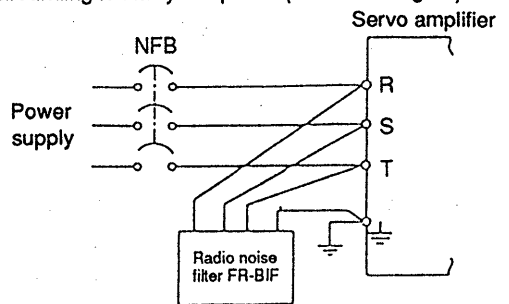
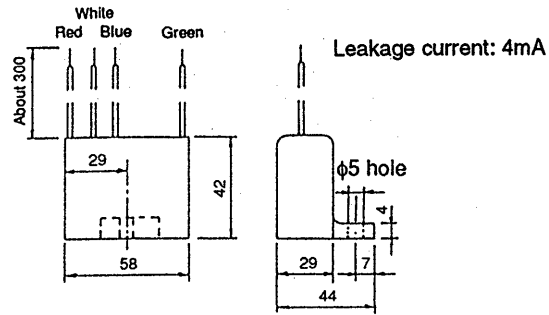
Connection chart	Outside dimensions drawing (Unit: mm)
<p>Make the connecting cables as short as possible. Grounding is always required. (Class 3 or higher)</p> 	 <p>Leakage current: 4mA</p>

6. Methods for Using the Auxiliary Equipment and Options

6-10 Selection of power supply and surge absorber for electromagnetic brake

The following are available for servo motor with electromagnetic brakes.

(1) Power supply

This unit is used when the exciting power (24VDC) for the electromagnetic brake is obtained from a 200VAC source. Use the following power supply or equivalent.

(Ex.) ZKF-W₁ type power supply unit

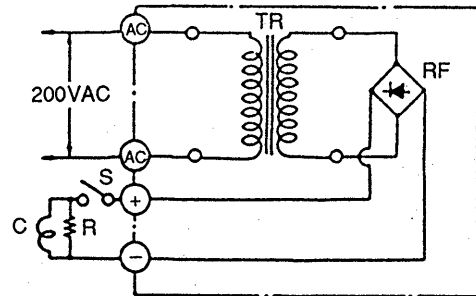
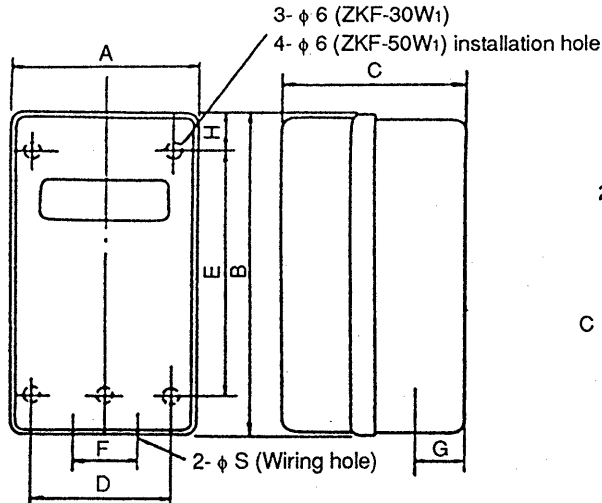

TR: Transformer
RF: Rectifier
R: Protective resistor or barrister
C: Exciter coil for brake
S: Switch

Outer dimensions of the ZKF-W₁ type power supply unit [mm]

Model	Power voltage AC (V)	Output voltage DC (V)	Output current (A)	A	B	C	D	E	F	G	H	S	Weight (kg)
ZKF-30W ₁	200	24	0.9	104	170	110	76	140	50	30	15	22	2.6
ZKF-50W ₁			1.8	135	225	130	95	165	50	45	30	28	3.8

(2) Surge absorber

When wiring the electromagnetic brake, always use a surge absorber. Use the following surge absorber or equivalent. Connect across the brake terminals in the servo motor terminal box. Insulate the wiring as shown in the diagram.

External dimensions [mm]

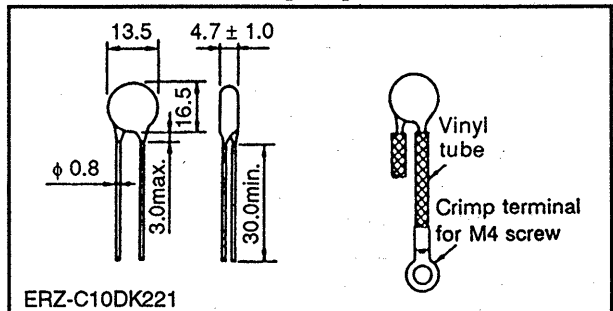

Maximum Rating					Maximum Limit Voltage		Static Capacity (Reference value)	Varistor Voltage Rating (Range) V _{1mA}
Permissible circuit voltage		Surge immunity	Energy immunity	Raged power	(A)	(V)	(pF)	(V)
AC (Vrms)	DC (V)	(A)	(J)	(W)	(A)	(V)	(pF)	(V)
140	180	500/time (Note)	5	0.4	25	360	300	220 (198 to 242)

Note: 1 time=8×20μsec

- (Ex.) • ERZ-C10DK221 (Made by Matsushita Electric)
• TNR-12G21K (Marcon Electronics)

6. Methods for Using the Auxiliary Equipment and Options

6-11 Leakage current breaker

High-frequency chopper current controlled by pulse width modulation flows in the AC servo circuit. Leakage current containing the harmonic contents is larger than that of a motor which is run with a commercial power supply. Leakage current during the low noise operation is larger than that during the non-low noise operation.

Select a leakage breaker as mentioned below, and ground the servo amplifier, servo motor, etc. securely. Make the input and output cables as short as possible, and also, make the grounding wire as long as possible (about 30cm) to minimize leak currents.

Selection

The amount of leakage current varies according to the cable and wire length, servo motor capacity and low noise/non-low noise operation. Select a leakage current breaker as mentioned below.

- Leakage current on the electric channel from the leakage current breaker to the input terminal of the servo amplifier: I_{g1} (mA)
(Obtain from Table 6-1.)
- Leakage current on the electric channel from the output terminal of the servo amplifier to the motor: I_{g2} (mA)
(Obtain from Table 6-1.)
- Leakage current when a filter is connected to the input side: I_{gn} (mA)
(4mA per one FR-BIF)
- Leakage current of the servo amplifier: I_{ga} (mA)
(Obtain from Table 6-3.)
- Leakage current of the servo motor: I_{gm} (mA)
(Obtain from Table 6-2.)

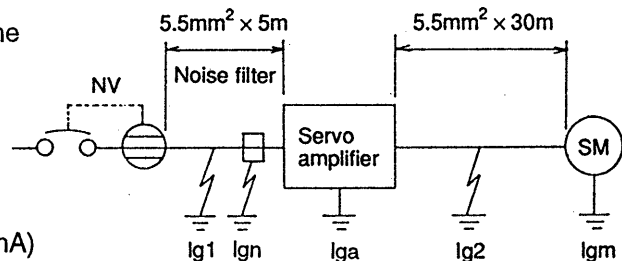

$$\text{Rated sensitivity current} \geq 10 \times \{I_{g1} + I_{gn} + I_{ga} + K \times (I_{g2} + I_{gm})\} \text{mA}$$

K: Constant considering the harmonic contents

(varies according to the frequency characteristics of the leakage breaker)

Models provided with countermeasures against harmonics and surge
(equivalent to MITSUBISHI NV-SF or FF): K=1

General models (equivalent to MITSUBISHI NV-CA, CS or SS): K=3

Table 6-1

Leakage current (I_{g1} , I_{g2}) when CV cable is laid in a metal conduit

Cable size (mm ²)	Leakage current per 1 km (mA)
2	13
3.5	17
5.5	33

Table 6-2

Leakage current of servo motor (I_{gm})

Servo motor	Leakage current (mA)	
HA-ME HA-FE	0.03 or less	
HA-SE	1kW or less	0.1
	1.2k to 2kW	0.2
	3k, 3.5kW	0.3

Table 6-3

Leakage current of servo amplifier

Servo amplifier capacity (kW)	Leakage current (mA)
0.1 to 0.6	0.1
0.7 to 3.5	0.15

Table 6-4

Leakage current breaker selection example

Model	Rated sensitivity current of leakage breaker
All servo amplifiers	15mA

Note: The above value assumes that the wiring distance is 5m.

7. Setting

7-1 List of control variables

The following symbols and variables are used for selecting the correct servo.

<p>T_a : Acceleration torque [N·m]</p> <p>T_d : Deceleration torque [N·m]</p> <p>T_{Ma} : Servo motor torque necessary for acceleration [N·m]</p> <p>T_{Md} : Servo motor torque necessary for deceleration [N·m]</p> <p>T_{LH} : Torque applied when the servo motor is stopping [N·m]</p> <p>T_L : Load torque converted into equivalent value on servo motor shaft [N·m]</p> <p>T_{LM} : Load torque converted into equivalent value on servo motor shaft during stopping [N·m]</p> <p>T_U : Unbalance torque [N·m]</p> <p>T_F : Load friction torque [N·m]</p> <p>T_{LO} : Load torque on load shaft [N·m]</p> <p>T_{rms} : Continuous effective load torque converted into equivalent value on servo motor shaft [N·m]</p> <p>J_L : Load inertia converted into servo motor shaft [kg·cm²]</p> <p>J_{LO} : Load inertia on load shaft [kg·cm²]</p> <p>J_M : Motor's rotor inertia [kg·cm²]</p> <p>N : Motor speed [r/min]</p> <p>N_O : Motor speed during fast feed [r/min]</p> <p>N_{LO} : Load shaft speed during fast feed [r/min]</p> <p>V : Motion part speed [mm/min]</p> <p>V_O : Motion part speed during fast feed [mm/min]</p> <p>P_B : Ball screw lead [mm]</p> <p>Z_1 : No. of gear teeth on servo motor shaft</p> <p>Z_2 : No. of gear teeth on load gear</p> <p>n : Gear ratio</p> $n = \frac{Z_2}{Z_1}$ <p>Speed reduced when $n > 1$, Speed increased when $n < 1$</p>	<p>P_t : No. of feedback pulses in positioning servo [pulse/rev]</p> <p>f : Input pulse frequency in positioning servo [pps]</p> <p>f_o : Input pulse frequency during fast feed in positioning servo [pps]</p> <p>T_{psa} : Acceleration time constant of frequency command in positioning servo [sec]</p> <p>T_{psd} : Deceleration time constant of pulse frequency command in positioning servo [sec]</p> <p>K_p : Position loop gain [sec⁻¹]</p> <p>T_p : Position loop time constant ($T_p = 1/K_p$) [sec]</p> <p>K_v : Speed loop gain [sec⁻¹]</p> <p>T_v : Speed loop time constant ($T_v = 1/K_v$) [sec]</p> <p>$\Delta \ell$: Movement amount per feedback pulse in positioning servo [mm/pulse]</p> <p>$\Delta \ell_o$: Movement amount per command pulse in positioning servo [mm/pulse]</p> <p>ℓ : Movement amount [mm]</p> <p>P : Number of input command pulses in positioning servo [pulse]</p> <p>t_s : Stop settling time in positioning servo [sec]</p> <p>t_o : Positioning time [sec]</p> <p>t_c : Time of constant rpm of servo motor in 1 cycle [sec]</p> <p>t_ℓ : Stopping time in 1 cycle [sec]</p> <p>$\Delta \varepsilon$: Positioning accuracy [mm]</p> <p>ε : No. of droop pulses [pulse]</p> <p>$\Delta \theta$: Load shaft rotation angle per pulse in positioning servo [degree/pulse]</p> <p>e : Euler constant = 2.71828</p> <p>ΔS : Movement amount per servo motor revolution [mm]</p>
---	--

7. Setting

7-2 Position resolution and parameter setting

The position resolution (movement amount per feedback pulse Δl) is determined from the movement amount per servo motor revolution ΔS and number of detector feedback pulses P_f . The following equation shows this.

$$\Delta l = \frac{\Delta S}{P_f} \dots\dots\dots (7-1)$$

- Δl : movement amount per pulse [mm]
- ΔS : movement amount per servo motor revolution [mm]
- P_f : number of feedback pulses [pulse/rev]

The value for Δl is related to the equation (7-1) and the value in the control system is fixed when the drive system and encoder are determined. However, the movement amount per command pulse can be set with parameters.

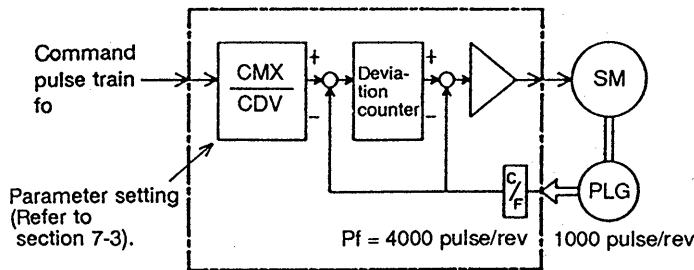

As shown above, the command pulse is multiplied by CMX/CDV to become the position control pulse. Therefore the movement amount per command pulse, Δl_o , is expressed with the following equation.

$$\Delta l_o = \frac{\Delta S}{P_f} \times \left[\frac{CMX}{CDV} \right] = \Delta l \times \left[\frac{CMX}{CDV} \right] \dots\dots\dots (7-2)$$

Using the above relation, the movement amount for command pulse can be set to a number without fraction.

7. Setting

Setting example

Obtain the parameter value for $\Delta l = 0.01$ [mm] in the drive system with a ball screw lead

$P_B = 10$ [mm], reduction ratio $1/n = 1$.

The MR-FE encoder feedback pulse is $P_f = 4000$ [pulse/rev].

$\Delta S = 10$ [mm] so with equation (7-2), the following is obtained.

$$\left[\frac{CMX}{CDV} \right] = \Delta l_0 \times \frac{P_f}{\Delta S} = 0.01 \times \frac{4000}{10} = 4$$

Therefore, the parameters are set as $CMX=4$ and $CDV=1$.

Relationship of position resolution Δl and total accuracy

Total accuracy (machine's positioning accuracy) is the sum of the electrical difference and mechanical difference. Therefore, the electrical system difference is normally set so that it does not influence overall difference.

Refer to the equation below as a guideline.

$$\Delta l < \left[\frac{1}{5} \text{ to } \frac{1}{10} \right] \times \Delta \varepsilon \dots\dots\dots (7-3)$$

Here: $\Delta \varepsilon$: positioning accuracy [mm]

7. Setting

7-3 Servo motor speed and command pulse frequency

The servo motor is commanded to run at a speed where the command pulse and feedback pulse are equivalent. Therefore, the command pulse frequency and feedback pulse frequency are equivalent, so the relation including the parameter command pulse multiplication (CMX, CDV) set value is shown below.

$$f_o \times \frac{CMX}{CDV} = 4000 \times \frac{N_o}{60} \dots\dots\dots (7-4)$$

Here: f_o : command pulse frequency [pps]
 CMX : command pulse multiplication numerator
 CDV : command pulse multiplication denominator
 N_o : servo motor speed [r/min]

Use the above equation to obtain the command pulse multiplication and command pulse frequency for rotating the servo motor at N_o .

Setting example 1

Setting example for command pulse multiplication (CMX, CDV) when using AD71.

Obtain the command pulse multiplication to operate the servo motor at 3000 [r/min] with an input pulse train frequency of 200 [kpps].

With equation (7-4):

$$\left[\frac{CMX}{CDV} \right] = 4000 \times \frac{N_o}{60} \times \frac{1}{f_o} = 4000 \times \frac{3000}{60} \times \frac{1}{200 \times 10^3} = 1$$

Therefore, the parameter and set to CMX=1 and CDV=1.

Setting example 2

Obtain the command pulse frequency that sets the servo motor speed N_o to 3000 [r/min]. Here, the command pulse multiplication is CMX/CDV = 1.

With equation (7-4):

$$f_o = 4000 \times \frac{N_o}{60} \times \frac{CVD}{CMX} = 4000 \times \frac{3000}{60} \times 1 = 200 \times 10^3 \text{ [pps]} = 200 \text{ [kpps]}$$

When using HA-FE at 4000r/min, the input pulse is limited to 200kpps, so the electronic gear ratio is set to that below.

$$\left[\frac{CMX}{CDV} \right] = 4000 \times \frac{4000}{60} \times \frac{1}{200 \times 10^3} = \frac{4}{3}$$

Therefore, the parameter are set to CMX=4 and CDV=3.

7. Setting

7-4 Stopping characteristics of the servo motor

(1) Droop pulses (ϵ) (DEVIATION)

When operating the servo with a pulse train command, the encoder feedback pulses are delayed during acceleration. The difference between the command pulses and feedback pulses are called droop pulses. The droop pulses are accumulated in the servo amplifier's deviation counter. The following equation defines the relationship between the command frequency(f_o), the position loop gain(K_p), and the number of droop pulses(ϵ).

$$\epsilon = \frac{f_o}{K_p} \text{ [pulse]} \dots\dots\dots (7-5)$$

In the MELSERVO-J, K_p can be adjusted from 5 to 100 [sec^{-1}]. It is set to $K_p=25 \text{ [sec}^{-1}\text{]}$ at the factory. Here, if the command pulse frequency is 200 [kpps], the droop pulses will be the following, according to the above equation (7-5).

$$\epsilon = \frac{200 \times 10^3}{25} = 8000 \text{ [pulse]}$$

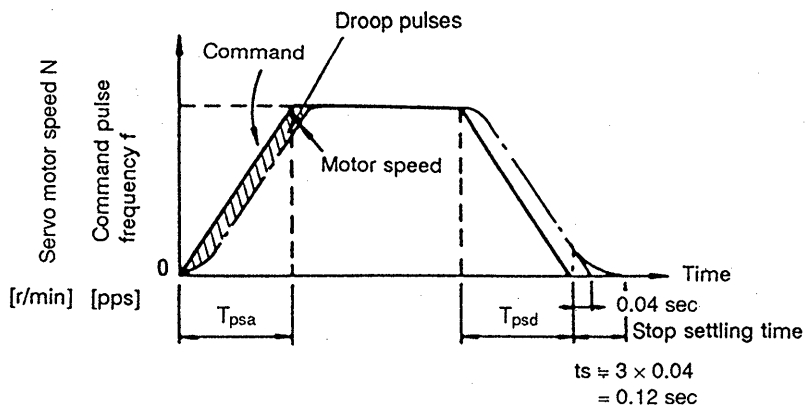

(2) Stop settling time (t_s) during linear deceleration

The servo amplifier during operation has droop pulses, so a stop settling time (t_s) is required from the time the command reaches 0 to when the servo motor stops. The command positioning time and machine positioning time will differ.

Set the operation pattern while taking the stop settling time into consideration.

The t_s value can be obtained from the next equation.

$$t_s \cong 3 \times T_P = 3 \times \frac{1}{K_P} \text{ [sec]} \dots\dots\dots (7-6)$$

* When the factory default setting $K_p=25 \text{ [sec}^{-1}\text{]}$ is used, $t_s \cong 0.12 \text{ [sec]}$. Refer to above diagram.

(Note) The stop settling time (t_s) indicates the time required for the servo motor to stop in the necessary position accuracy range. This does not always mean that the servo motor has stopped completely. Thus, at high cycle rates, a larger value than the value obtained in the equation (7- 6) must be considered when there is no allowance in the positioning accuracy for the movement amount per pulse ($\Delta\theta$).

The t_s will differ depending on the moving part conditions. If the load friction torque is especially large, the movement may be unstable near the stopping position.



7. Setting

7-5 Servo motor selection

To select a servo motor, the load torque and inertia must first be calculated. Next, a motor is selected according to these initial calculations. Then, the load of the motor is included in further calculations to determine if the initial motor selected will provide the necessary performance.

(1) Initial selection of servo motor capacity

When the load torque (T_L) and load inertia (J_L) have been calculated. Select a servo motor using motor rated torque $> T_L$, servo motor inertia $J_M > J_L/3$ as a guideline. Find the torque for acceleration/deceleration, and the continuous effective load torque following the steps in (2) and then verify the selection.

For frequent positioning, the J_L value should be as small as possible. If positioning is infrequent, the J_L value can be slightly larger than the above conditions.

(2) Acceleration/deceleration torque

The equation for obtaining the acceleration/deceleration torque with the following pattern is shown.

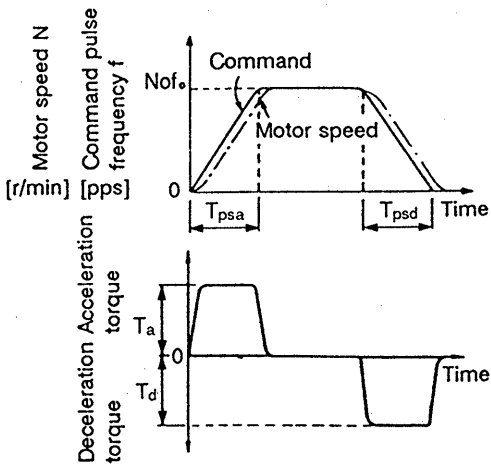

• Acceleration torque

$$T_a = \frac{(J_L + J_M) \times N_o}{9.55 \times 10^4} \times \frac{1}{T_{psa}} \dots\dots\dots (7-7)$$

• Deceleration torque

$$T_d = \frac{(J_L + J_M) \times N_o}{9.55 \times 10^4} \times \frac{1}{T_{psd}} \dots\dots\dots (7-8)$$

7. Setting

(3) Torque required for operation

The highest torque is applied to the servo motor during acceleration. If the torque required for the servo motor during acceleration obtained in the following equation exceeds the maximum servo motor torque, acceleration will not be possible in the commanded time. Confirm that the calculated value is lower than the motor's maximum servo motor torque. Normally, a friction load is applied during deceleration, so only the acceleration torque needs to be considered.

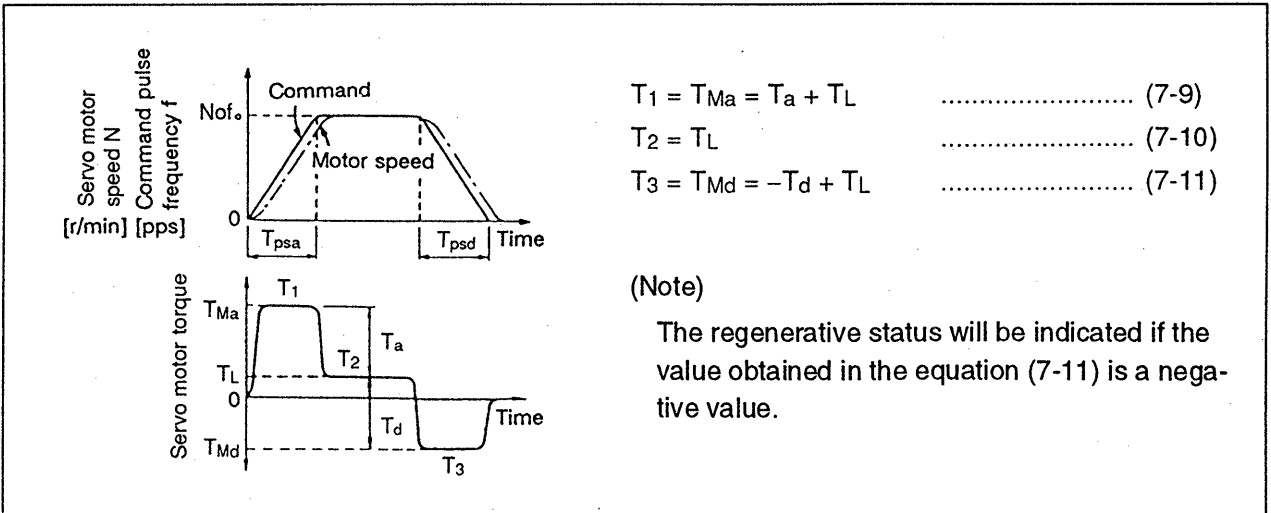

7. Setting

(4) Continuous effective load torque

If the torque required for the servo motor changes with the time, the continuous effective load torque obtained in the following equation must be lower than the servo motor's rated torque.

Always confirm this torque and check that the servo motor does not overheat when carrying out frequent positioning.

There may be a servo motor torque delay at acceleration or deceleration due to a delay in the control system. But, to simplify the calculation, the calculation assumes that a constant acceleration/deceleration torque is applied during T_{psa} and T_{psd} . The equation for the continuous effective load torque for the following operation pattern is given below.

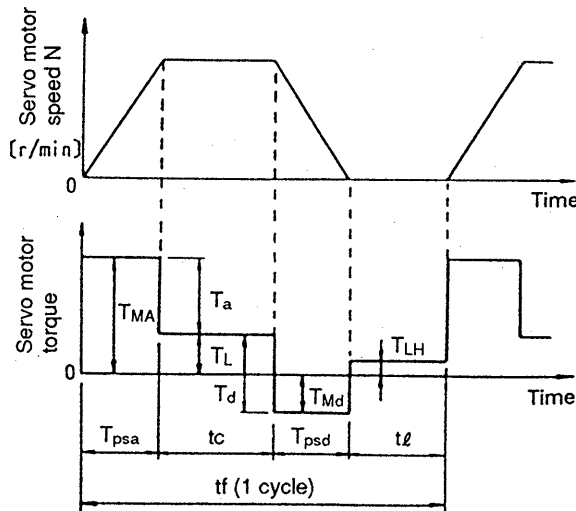

$$T_{rms} = \sqrt{\frac{T_{Ma}^2 \times T_{psa} + T_L^2 \times t_c + T_{Md}^2 \times T_{psd} + T_{LH}^2 \times t_l}{t_f}} \dots\dots\dots(7-12)$$

Note: T_{LH} in the diagram shows the torque applied during stopping. A torque is applied to the servo motor especially when stopping during vertical operations. During vertical drive, the unbalanced torque T_U will be T_{LH} .

7. Setting

7-6 Load torque equations

The main load torque equations are shown in Table 7-1.

Table 7-1 Load torque equations

Type	Mechanism	Equation
Linear movement		$T_L = \frac{F}{2 \times 10^3 \pi \eta} \times \left[\frac{V}{N} \right] = \frac{F \times \Delta s}{2 \times 10^3 \pi \eta} \dots\dots\dots(7-13)$ <p>F: Shaft direction force of the machine in linear motion [N] η: Drive system efficiency</p> <p>F in the above equation is obtained with the equation (7-19) when moving a table, for example, as shown in the diagram.</p> $F = F_c + \mu (W \times g + F_G) \dots\dots\dots(7-14)$ <p>F_c: Shaft direction force applied on moving part [N] F_G: Tightening force of the table guide plate [N] W: Total weight of the moving part [kg] g: Acceleration of gravity [9.8m/s²] μ: Friction coefficient</p>
Rotary movement		$T_L = \frac{1}{n} \times \frac{1}{\eta} \times T_{L0} + T_F \dots\dots\dots(7-15)$ <p>T_{L0}: Load torque on the load shaft [N·m] T_F: Load friction torque converted into equivalent value on servo motor shaft [N·m]</p>
Vertical movement		<p>During rising</p> $T_L = T_U + T_F \dots\dots\dots(7-16)$ <p>During lowering</p> $T_L = -T_U \times \eta^2 + T_F \dots\dots\dots(7-17)$ <p>T_U: Unbalanced torque [N·m] T_F: Friction torque of the moving part [N·m]</p> $T_U = \frac{(W_1 - W_2) \times g}{2 \times 10^3 \pi \eta} \times \left[\frac{V}{N} \right] = \frac{(W_1 - W_2) \times g \times \Delta S}{2 \times 10^3 \pi \eta} \dots\dots\dots(7-18)$ $T_F = \frac{\mu \times (W_1 + W_2) \times g \times \Delta S}{2 \times 10^3 \pi \eta} \dots\dots\dots(7-19)$ <p>W₁: Load weight [kg] W₂: Counter weight [kg] η: Drive part efficiency μ: Friction coefficient</p>



7. Setting

7-7 Load inertia equations

The main load inertia equations are shown in Table 7-2.

Table 7-2 Load inertia equations

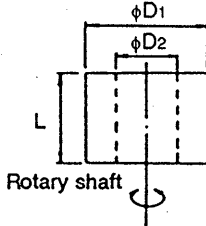
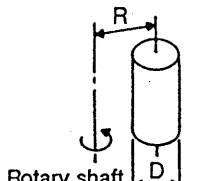
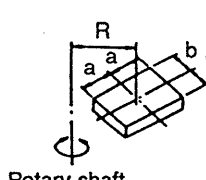
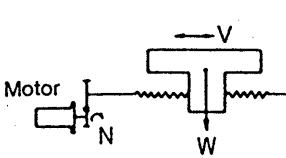
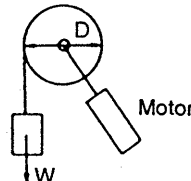
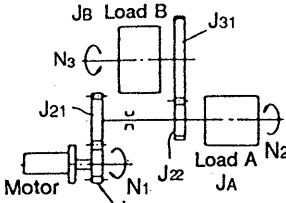
Type	Mechanism	Equation
Cylinder	Rotary shaft is at cylinder center 	$J_{LO} = \frac{\pi \times \rho \times L}{32} \times (D_1^4 - D_2^4) = \frac{W}{8} \times (D_1^2 - D_2^2) \dots \dots \dots (7-20)$ <p> J_{LO} : Load inertia [kg·cm²] ρ : Cylinder material density [kg·cm³] L : Cylinder length [cm] D_1 : Cylinder outer diameter [cm] D_2 : Cylinder inner diameter [cm] W : Cylinder weight [kg] </p> Reference data: material density Steel : 7.8×10^{-3} [kg/cm ³] Aluminum : 2.7×10^{-3} [kg/cm ³] Copper : 8.96×10^{-3} [kg/cm ³]
	When rotary shaft and cylinder shaft are off 	$J_{LO} = \frac{W}{8} \times (D^2 + 8R^2) \dots \dots \dots (7-21)$
Square block		$J_{LO} = W \times \left[\frac{a^2 + b^2}{3} + R^2 \right] \dots \dots \dots (7-22)$ <p>a, b, R: Left diagram [cm]</p>
Object which moves linearly		$J_L = W \times \left[\frac{v}{600\omega} \right] = W \times \left[\frac{1}{2\pi N} \times \frac{v}{10} \right]^2 = W \times \left[\frac{\Delta S}{20\pi} \right]^2 \dots \dots \dots (7-23)$ <p> J_L : Load inertia converted into equivalent value on servo motor shaft [kg·cm²] V : Speed of object moving linearly [mm/min] N : Servo motor speed [r/min] ΔS : Servo movement amount of object moving linearly per motor one rotation [mm] </p>
Object that is hung with pulley		$J_L = W \times \left[\frac{D}{2} \right]^2 + J_P \dots \dots \dots (7-24)$ <p> J_P : Pulley inertia [kg·cm²] D : Pulley diameter [cm] </p>
Converted load		$J_L = J_{11} + (J_{21} + J_{22} + J_A) \times \left[\frac{N_2}{N_1} \right]^2 + (J_{31} + J_B) \times \left[\frac{N_3}{N_1} \right]^2 \dots \dots \dots (7-25)$ <p> J_A, J_B : Load A, B inertia [kg·cm²] J_{11} to J_{31} : Inertia [kg·cm²] N_1 to N_3 : Speed of each shaft [r/min] </p>

7. Setting

7-8 Procedure for setting the mechanical origin

To return the system to the origin with the MELSERVO-J, use a near-zero point dog or actuator. The method and precautions for setting the mechanical origin are given below.

In the following origin return, an actuator and the zero pulse signal of a servo motor encoder are used to set the mechanical origin.

When a general positioning module (e.g. AD71) is used, the sequence of events is as shown below.

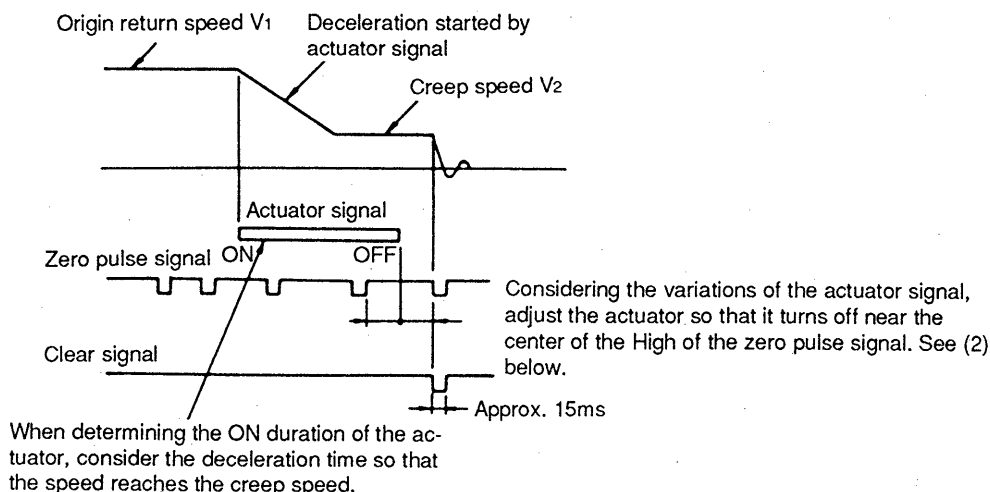

Fig. 7-1 Origin return using the actuator

- (1) When determining the ON duration of the actuator, consider the delay time of the control and the deceleration time so that the creep speed is attained. If the near-zero point dog turns OFF during deceleration, precise origin return cannot be performed.

- Travel distance L_1 in the chart can be obtained by the general formula given below. ... Formula (7-26)

- ON duration of the actuator LD [mm] must be longer than L_1 obtained by formula (7-26). ... Formula (7-27)

$$L_1 = \frac{1}{60} V_1 \times t_1 + \frac{1}{120} V_1 \times t_d \left\{ 1 - \left(\frac{V_2}{V_1} \right)^2 \right\} \dots (7-26)$$

$$LD > L_1 \dots (7-27)$$

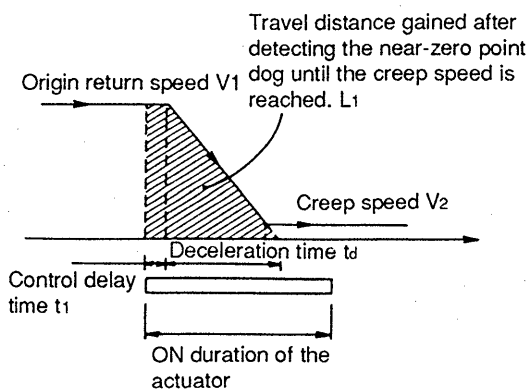

where,

V_1, V_2 : as shown in the chart [mm/min]

t_1, t_d : same as above [sec]

L_1 : same as above [mm]

LD : same as above [mm]

- (2) Set the end (OFF position) of the actuator signal at the middle of two ON positions (Lows) of the zero pulse signal. If it is set near either ON position of the zero pulse signal, the positioning module is liable to misdetect the zero pulse signal. In this case, a fault will occur, e.g. the origin will shift by one revolution of the servo motor.

The zero pulse output position is shown on the 7-segment display of the servo amplifier.

- (3) Set the creep speed so that the machine is not shocked when the operation comes to a stop. The operation instantly stops since a clear (CR) signal is given to the servo amplifier immediately when a zero pulse signal is detected.

7. Setting

7-9 Example of servo motor selection

Selection example 1

Machine specifications

— System configuration —

Speed of moving part during fast feed

Speed of moving part during fast feed	$V_o = 30000 \text{ mm/min}$
Movement amount per pulse	$\Delta \ell = 0.005 \text{ mm}$
Movement amount	$\ell = 400 \text{ mm}$
Positioning time	$t_o = 1 \text{ sec or less}$
No. of feeds (Operation cycle)	40 times/min. $t_r = 1.5 \text{ sec.}$
Gear ratio	$n = 8/5$
Moving part weight	$W = 60 \text{ kg}$
Drive part efficiency	$\eta = 0.8$
Friction coefficient	$\mu = 0.2$
Ball screw lead	$P_B = 16 \text{ mm}$
Ball screw diameter	20 mm
Ball screw length	500 mm
Gear diameter (motor shaft)	25 mm
Gear diameter (load shaft)	40 mm
Gear teeth width	10 mm

(1) Selection of control parameter

a. Setting of electronic gears (pulse multiplication numerator, denominator)

The following relation is established between the multiplication setting and movement amount per pulse $\Delta \ell$.

$$\Delta \ell = \frac{(\text{Ball screw lead})}{4000 \times (\text{Gear ratio})} \times \left[\frac{\text{CMX}}{\text{CDV}} \right]$$

When the machine specification are substituted in the above equation:

$$\frac{\text{CMX}}{\text{CDV}} = 0.005 \times \frac{4000 \times 8/5}{16} = 2$$

OK if the $\frac{\text{CMX}}{\text{CDV}}$ ratio is within 1/50 to 20.

b. Input pulse train frequency f_o for fast feed

$$f_o = \frac{V_o}{60 \times \Delta \ell} = \frac{30000}{60 \times 0.005} = 100000 \text{ pps}$$

OK if f_o is 200kpps or less

7. Setting

(2) Servo motor speed

$$N_o = \frac{V_o}{P_B} \times n = 3000 \text{ r/min}$$

(3) Acceleration/deceleration time

$$T_{psa} = T_{psd} = t_o - \frac{l}{V_o/60} - t_s = 0.05 \text{ sec.}$$

* t_s : stop settling time. Here, this is assumed to be 0.15 sec.

(4) Operation pattern

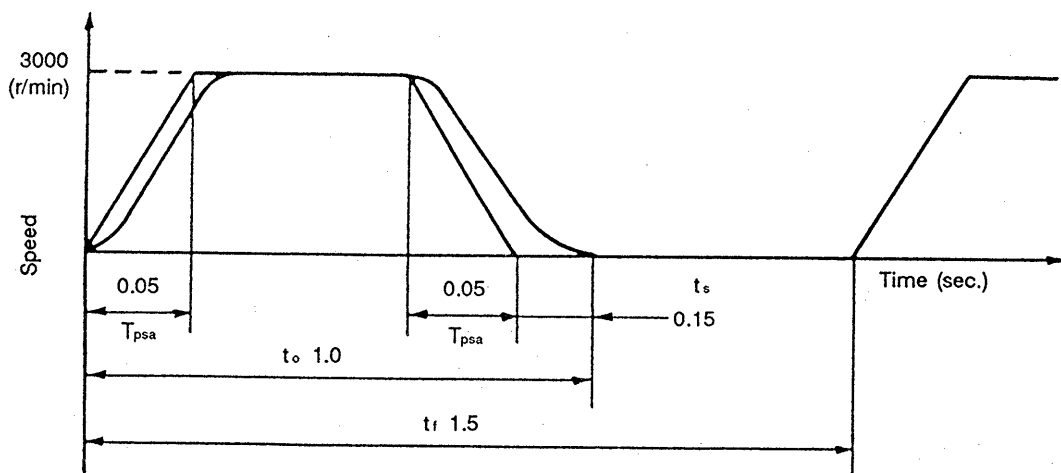

(5) Load torque (converted into equivalent value on motor shaft)

Movement amount per motor revolution

$$\Delta S = P_B \times \frac{1}{n} = 10 \text{ mm}$$

$$T_L = \frac{\mu \times W \times g \times \Delta S}{2 \times 10^3 \pi \eta} = 0.23 \text{ N} \cdot \text{m}$$

For conventional system of units

$$T_L = \frac{\mu W \times \Delta S}{20 \pi \eta} = 2.4 \text{ kgf} \cdot \text{cm}$$

(6) Load inertia (converted into equivalent value on servo motor shaft)

Moving part

$$L_{L1} = W \times \left[\frac{\Delta S}{20\pi} \right]^2 = 1.52 \text{ kg} \cdot \text{cm}^2$$

7. Setting

Ball screw

$$J_{L2} = \frac{\pi \times \rho \times L}{32} \times D^4 \times \left[\frac{1}{n} \right]^2 = 0.24 \text{ kg}\cdot\text{cm}^2$$

* $\rho = 7.8 \times 10^{-3} \text{ kg/cm}^3$ (iron)

Gear (servo motor shaft)

$$J_{L3} = \frac{\pi \times \rho \times L}{32} \times D^4 = 0.03 \text{ kg}\cdot\text{cm}^2$$

Gear (load shaft)

$$J_{L4} = \frac{\pi \times \rho \times L}{32} \times D^4 \times \left[\frac{1}{n} \right]^2 = 0.08 \text{ kg}\cdot\text{cm}^2$$

Full load inertia (converted into equivalent value on motor shaft)

$$J_L = J_{L1} + J_{L2} + J_{L3} + J_{L4} = 1.9 \text{ kg}\cdot\text{cm}^2$$

For conventional system of units

$$GD^2 = 4 \times J = 7.6 \text{ kgf}\cdot\text{cm}^2$$

(7) Temporary selection of servo motor

Selection conditions

Select HA-FE23 (200W) with:

- 1) Load torque < motor rated torque
- 2) Load inertia < 10 × motor inertia

(8) Acceleration/deceleration torque

Torque required for servo motor during acceleration

$$T_{Ma} = \frac{(J_L + J_M) \times N_o}{9.55 \times 10^4 \times T_{psa}} + T_L = 1.7 \text{ N}\cdot\text{m}$$

For conventional system of units

$$T_{Ma} = \frac{(GD_L^2 + GD_M^2) \times N_o}{37500 \times T_{psa}} + T_L = 17.2 \text{ kgf}\cdot\text{cm}$$

Torque required for servo motor during deceleration

$$T_{Md} = - \frac{(J_L + J_M) \times N_o}{9.55 \times 10^4 \times T_{psd}} + T_L = -1.2 \text{ N}\cdot\text{m}$$

For conventional system of units

$$T_{Md} = - \frac{(GD_L^2 + GD_M^2) \times N_o}{37500 \times T_{psd}} + T_L = -12.4 \text{ kgf}\cdot\text{cm}$$

7. Setting

The torque required for the motor during acceleration/deceleration must be lower than the servo motor maximum torque.

(9) Continuous effective load torque

$$T_{rms} = \sqrt{\frac{T_{Ma}^2 \times T_{psa} + T_L^2 \times t_c + T_{Md}^2 \times T_{psd}}{t_f}} = 0.41 \text{ N}\cdot\text{m}$$

For conventional system of units

4.2 kgf·cm

The continuous effective load torque must be lower than the servo motor rated torque.

(10) Torque pattern

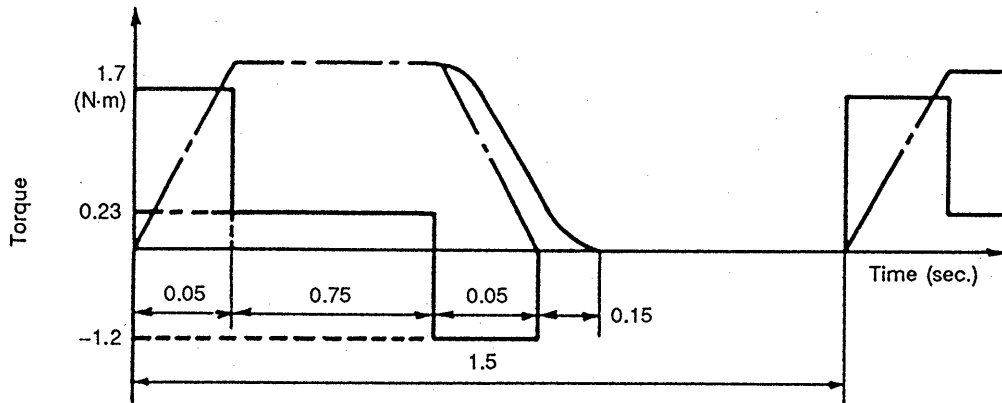

(11) Selection results

Servo motor HA-FE23 and servo amplifier MR-J20A are selected with the above conditions.

a. Parameter setting value

Motor series and type	(MTY)	23
Servo loop type	(STY)	0000
Command pulse multiplication numerator	(CMX)	2
Command pulse multiplication denominator	(CDV)	1

b. During fast feed

- Motor speed $N_o = 3000 \text{ r/min}$
- Input pulse train frequency $f_o = 100 \text{ kpps}$

c. Acceleration/deceleration time constant

$$T_{psa} = T_{psd} = 0.05 \text{ sec}$$

7. Setting

Selection example 2

Machine specifications

— System configuration —

Gear ratio	$n = 40$
Chain pitch	$P_c = 25.4$ (RS80) [mm]
Number of teeth of sprocket	$Z = 45$
Fast feed speed	$V_o = 55000$ [mm/min]
Head mass	$W_1 = 400$ [kg]
Workpiece mass	$W_2 = 50$ [kg]
Counterweight mass	$W_3 = 350$ [kg]
Chain mass	$W_4 = 10$ [kg]
Reduction gear inertia moment	$J_R = 12$ [kg·cm ²]
(converted into equivalent value on the servo motor shaft)	
Sprocket inertia moment	$J_s = 10000$ [kg·cm ²]
Feed amount per one time of positioning	$\ell = 700$ [mm]
Positioning time	$t_o = 1.2$ [sec]
Number of times of positioning	$f_s = 10 \times 2$ [times/min]
Positioning accuracy	$\Delta \varepsilon = 0.1$ [mm]
Driving unit efficiency	$\eta = 0.7$
Frictional coefficient	$\mu = 0.1$
Feed amount per pulse	$\Delta \ell_o = 0.01$ [mm/pulse]

(1) Parameter settings

(a) Servo amplifier electronic gear setting

$$\left(\frac{CMX}{CDX} \right) = \frac{P_f}{\Delta S} \times \Delta \ell = \frac{1600}{1143}$$

Setting

$CMX = 1600$
 $CDV = 1143$

(b) Command module AD71 setting

Motor speed during fast feed

$$N1 = \frac{V_o}{\Delta S} = \frac{55000}{25.4 \times 45/40} \approx 1925 \text{ [r/min]}$$

When the unit of feed of AD71 is PULSE

- Positioning speed (positioning data No. 2)

$$f_o = \frac{V_o}{\Delta \ell_o} \times \frac{1}{60} = \frac{55000}{0.01} \times \frac{1}{60} \approx 91667 \text{ [pps]}$$

Setting

9167

(= 91.667 [kpps])

- Positioning address (positioning data No. 3)

$$P = \frac{\ell}{\Delta \ell_o} = \frac{700}{0.01} = 70000 \text{ [pulse]}$$

Setting

7000

7. Setting

When the unit of feed of AD71 is mm

- Travel amount per pulse (parameter No. 2)
 $\Delta \ell_o = 0.01$ [mm] Setting 100
- Positioning speed (positioning data No. 2)
 $V_o = 55000$ [mm/min] Setting 5500
- Positioning address (positioning data No. 3)
 $\ell = 700 \times 10^3$ [μm] Setting 700 × 10⁴

(2) Calculation of load torque

Obtain the load torque from formulas (7-16) to (7-19) given in Section 7-6.

(a) When moving up

From formulas (7-16), (7-18) and (7-19), the following is obtained.

$$\begin{aligned}
 T_L &= T_U + T_F \\
 &= \frac{(W_1 + W_2 - W_3) \cdot g \cdot \Delta S}{2 \times 10^3 \pi \eta} + \frac{\mu(W_1 + W_2 + W_3 + W_4) \cdot g \cdot \Delta S}{2 \times 10^3 \pi \eta} \\
 &= \frac{(400 + 50 - 350) \times 9.8 \times \frac{25.4 \times 45}{40}}{2 \times 10^3 \pi \times 0.7} + \frac{0.1 \times (400 + 50 - 350 + 10) \times 9.8 \times \frac{25.4 \times 45}{40}}{2 \times 10^3 \pi \times 0.7} \\
 &= 6.4 + 5.2 \\
 &= 11.6 \text{ [N}\cdot\text{m]}
 \end{aligned}$$

(b) When moving down

From formulas (7-17), (7-18) and (7-19), the following is obtained.

$$T_L = -T_U \cdot \eta^2 + T_F = -3.1 + 5.2 = 2.1 \text{ [N}\cdot\text{m]}$$

(3) Calculation of load inertia

(a) Inertia of movable object

Use formula (7-23) in Section 7-7 as follows.

$$\begin{aligned}
 J_{L1} &= (W_1 + W_2 + W_3 + W_4) \times \left(\frac{\Delta S}{20\pi} \right)^2 \\
 &= (400 + 50 + 350 + 10) \times \left(\frac{25.4 \times 45/40}{20\pi} \right)^2 = 168 \text{ [kg}\cdot\text{cm}^2]
 \end{aligned}$$

(b) Inertia moment of the sprocket converted to the equivalent value on the servo motor shaft

$$\begin{aligned}
 J_{L2} &= J_s \times \left(\frac{1}{n} \right)^2 \\
 &= 10000 \times \left(\frac{1}{40} \right)^2 = 6.25 \text{ [kg}\cdot\text{cm}^2]
 \end{aligned}$$

(c) Load inertia converted to the equivalent value on all servo motor shafts

This is obtained as the sum of (a) and (b) mentioned above and the reduction gear inertia.

$$\begin{aligned}
 J_L &= J_{L1} + J_{L2} + J_R \\
 &= 168 + 6.25 + 12 = 186.25 \text{ [kg}\cdot\text{cm}^2]
 \end{aligned}$$

7. Setting

(4) Provisional selection of servo motor

Considering the load values obtained in (2) and (3) above, provisionally select the HA-SE352 (with electromagnetic brake) (rated torque $T_M = 16.7$ [N·m] and the servo motor inertia $J_M = 131$ [kg·cm²]).

(5) Calculation of the operation pattern

Since the operation is performed as up and down movements, the motor speed and torque patterns will be as shown below.

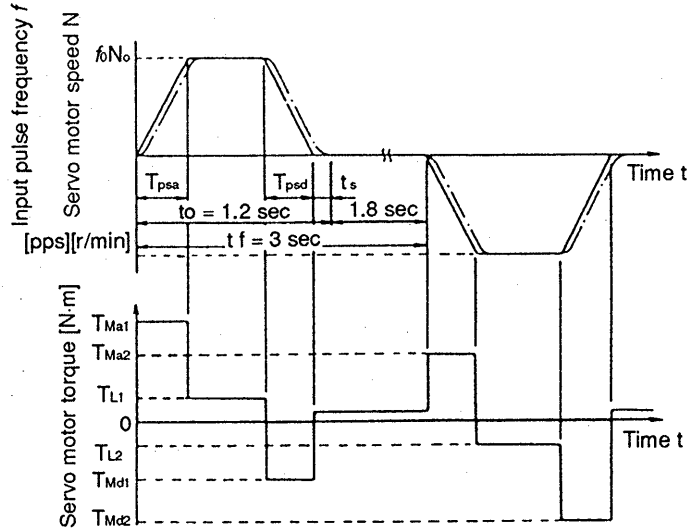

Calculate the acceleration and deceleration times required for positioning performed under the conditions of $t_o = 1.2$ (sec) or less and $l = 700$ (mm), shown in the figure above, as given below. To increase the stopping accuracy, determine t_s as follows.

$$\begin{aligned} t_s &= 5 \times T_p \\ &= 5 \times 0.04 = 0.2 \text{ [sec]} \end{aligned}$$

Calculate as follows.

$$\begin{aligned} T_{Psa} &= t_o - t_s - \frac{l}{V_o} \times 60 \\ &= 1.2 - 0.2 - \frac{700}{55000} \times 60 \approx 0.24 \text{ [set]} \end{aligned}$$

(6) Calculation of the acceleration and deceleration torque

Since $T_{psa} = T_{psd} = 0.24$ (sec) is substantially larger than $T_p = 0.04$ (sec), calculate the acceleration and deceleration torque using simplified formula (7-7).

$$\begin{aligned} T_a = T_d &= \frac{(J_L + J_B + J_M) \times N_o}{9.55 \times 10^4} \times \frac{1}{T_{psa}} \\ &= \frac{(186 + 5 + 131) \times 1925}{9.55 \times 10^4} \times \frac{1}{0.24} = 27.0 \text{ [N·m]} \end{aligned}$$

Note: J_B is the brake inertia moment of the motor with brake.

The servo motor torque values required during acceleration and deceleration are as follows.

When moving up

$$\begin{aligned} T_{Ma1} &= T_a + T_U + T_F = 38.6 \text{ [N·m]} \\ T_{L1} &= T_U + T_F = 11.6 \text{ [N·m]} \\ T_{Md1} &= -T_d + T_U + T_F = -15.4 \text{ [N·m]} \end{aligned}$$

When moving down

$$\begin{aligned} T_{Ma2} &= T_a - T_U \cdot \eta^2 + T_F = 29.1 \text{ [N·m]} \\ T_{L2} &= -T_U \cdot \eta^2 + T_F = 2.1 \text{ [N·m]} \\ T_{Md2} &= -T_d - T_U \cdot \eta^2 + T_F = -24.9 \text{ [N·m]} \end{aligned}$$

7. Setting

When stopping

Unbalance torque $T_U = 6.4$ [N·m]

The maximum torque values T_{Ma} and T_{Md} provisionally set with HA-SE352 are 50.1 [N·m] or less, which are allowable.

Since the maximum torque of the HA-SE352 selected provisionally is 50.1 [N·m] or less, both T_{Ma} and T_{Md} are acceptable.

(7) Calculation of continuous effective load torque

Confirm that the continuous effective load torque obtained from formula (7-12) using the operation pattern and required servo motor torque obtained in (2), (5) and (6) above is not larger than the servo motor's rated torque.

$$T_{rms} = \sqrt{\frac{38.6^2 \times 0.24 + 11.6^2 \times 0.52 + (-15.4)^2 \times 0.24 + 6.4^2 \times 2 \times 2 + 29.1^2 \times 0.24 + 2.1^2 \times 0.52 + (-24.9)^2 \times 0.24}{3 \times 2}}$$

$$= 12.9 \text{ [N·m]}$$

This is less than the rated torque, 16.7 [N·m], of provisionally selected motor HA-SE352 and is therefore acceptable.

(8) Necessity of regenerative option

Inertia ratio $m = \frac{186 + 4.25}{131} = 1.45$ Note: Magnetic brake must be added to the load.

Number of times of positioning $f_s = 10 \times 2$ [times/min]

If a regenerative option is added externally, allowable brake duty is calculated as given in Section 9-4 as follows.

$$\text{Tolerable duty} = \frac{67}{m + 1} = \frac{67}{1.45 + 1} = 27.3 \text{ [times/min]}$$

And, this satisfies the specification value (20 times/min).

Regenerative option: Necessary

Note: If the brake duty on the machine side is not satisfactory even if a regenerative option is used, refer to Section 9-4 and calculate the regenerative energy and the allowable frequency.

(Example)

Calculate the regenerative energy by using the formula in Section 9-4 and required servo motor torque in respective operation section. The total of the regenerative energy is given in the table below.

Operation section	Required servo motor torque [N·m]	Energy E.[J]	Driving/Regenerative
(1)	38.6	934	Driving
(2)	11.6	1216	Driving
(3)	-15.4	-372	Regenerative
(4), (8)	6.4	0 (regenerative energy)	Driving
(5)	29.1	704	Driving
(6)	2.1	220	Driving
(7)	-24.9	-602	Regenerative
Total E of ⊖ energies at (1) to (8)		-974	



7. Setting

Regenerative power P_r is calculated as follows by using the total E of \ominus energies, mentioned above, which is the total regenerative energy in one cycle ($t_r = 6$ [sec]).

$$P_r = \frac{E_r}{t_r} = \frac{833.2}{6} = 138 \text{ [W]} \quad \left(P_r = \frac{n \times E_s - E_A - E_c}{t_r} = \frac{9 \times 974 - 7 \times 48 - 40}{6} \right)$$

The values shown above are larger than the values of the brake built in the servo amplifier given in a table in Section 9-4 and smaller than the values of the regenerative option.

Judging from the above, the operation is possible when a regenerative option is used.

(9) Motor's magnetic brake

Select a motor equipped with a magnetic brake to prevent object from falling at power failures or when the power is switched OFF.

Result of selection

<ul style="list-style-type: none"> • Servo motor (with magnetic brake) • Servo amplifier • Regenerative option • Parameter settings 	<p>HA-SE352B</p> <p>MR-J350A</p> <p>MR-RB30</p>						
<table border="1" style="width: 100%; border-collapse: collapse;"> <tr> <td style="padding: 2px;">Servo loop type (STY)</td> <td style="text-align: center; padding: 2px;">0100</td> </tr> <tr> <td style="padding: 2px;">Command pulse multiplication numerator (CMX)</td> <td style="text-align: center; padding: 2px;">1600</td> </tr> <tr> <td style="padding: 2px;">Command pulse multiplication denominator (CDV)</td> <td style="text-align: center; padding: 2px;">1143</td> </tr> </table>		Servo loop type (STY)	0100	Command pulse multiplication numerator (CMX)	1600	Command pulse multiplication denominator (CDV)	1143
Servo loop type (STY)	0100						
Command pulse multiplication numerator (CMX)	1600						
Command pulse multiplication denominator (CDV)	1143						
<ul style="list-style-type: none"> • Servo motor speed in fast feed • Acceleration/deceleration time constant • Motor torque required during acceleration (maximum) • Servo motor torque required during deceleration (maximum) • Continuous effective load torque 	<p>$N_o = 1925$ [r/min]</p> <p>$T_{PSa} = T_{PSd} = 0.24$ [sec]</p> <p>$T_{Ma} = 38.6$ [N·m]</p> <p>$T_{Md} = -24.9$ [N·m]</p> <p>$T_{rms} = 12.9$ [N·m]</p>						

Calculation with customary units system

Specifications of the machine

Calculations with the SI units system are the same as those with customary units system except the following items.

Item	Conversion formula [unit]
Reduction gear GD^2	$GD^2_R = 4 \times J_R = 48$ [kgf·cm ²]
Sprocket GD^2	$GD^2_S = 4 \times J_S = 40000$ [kgf·cm ²]

Note: The same value applies to weight and mass.

(1) Parameter settings Same as in the SI units system.

7. Setting

(2) Calculation of load torque

(a) When moving up

$$\begin{aligned}
 T_L &= T_U + T_F \\
 &= \frac{(W_1 + W_2 - W_3) \times \Delta S}{20\pi\eta} + \frac{\mu(W_1 + W_2 + W_3 + W_4) \times \Delta S}{20\pi\eta} \\
 &= \frac{(400 + 50 - 350) \times \frac{25.4 \times 45}{40}}{20\pi \times 0.7} + \frac{0.1 \times (400 + 50 - 350 + 10) \times \frac{25.4 \times 45}{40}}{20\pi \times 0.7} \\
 &= 6.50 + 5.26 \\
 &= 117.6 \text{ [kgf}\cdot\text{cm]}
 \end{aligned}$$

(b) When moving down

$$T_L = -T_U \times \eta^2 + T_F = -31.9 + 52.6 = 20.7 \text{ [kgf}\cdot\text{cm]}$$

(3) Calculation of GD²

(a) GD² of movable object

$$GD_{L1}^2 = 4 \times (400 + 50 + 350 + 10) \times \left(\frac{25.4 \times 45/40}{20\pi} \right)^2 = 670 \text{ [kgf}\cdot\text{cm}^2]$$

(b) GD² of the sprocket converted to the equivalent value on the servo motor shaft

$$GD_{L2}^2 = GD_S^2 \times \left(\frac{1}{n} \right)^2 = 40000 \times \left(\frac{1}{40} \right)^2 = 25 \text{ [kgf}\cdot\text{cm}^2]$$

(c) GD² of the sprocket converted to the equivalent value on all servo motor shafts

$$GD_L^2 = GD_{L1}^2 + GD_{L2}^2 + GD_R^2 = 670 + 25 + 48 = 743 \text{ [kgf}\cdot\text{cm}^2]$$

(4) Provisional selection of servo motor

Torque and GD² values of the standard specification (Section 10-2) are given also in customary units system. Refer to those values and provisionally select the motor capacity. The result of provisional selection is the same as that with the SI units system.

(5) Calculation of the operation pattern Same as that with the SI units system.

(6) Calculation of the acceleration and deceleration torque

$$T_a = T_d = \frac{(GD_L^2 + GD_B^2 + GD_M^2) \times No}{37500 \times T_{PSa}} = \frac{(743 + 17 + 525) \times 1925}{37500 \times 0.24} = 275 \text{ [kgf}\cdot\text{cm]}$$

The motor torque values required during acceleration and deceleration are as follows.

When moving up

$$\begin{aligned}
 T_{Ma1} &= T_a + T_U + T_F = 392.6 \text{ [kgf}\cdot\text{cm]} \\
 T_{L1} &= T_U + T_F = 117.6 \text{ [kgf}\cdot\text{cm]} \\
 T_{Md1} &= -T_d + T_U + T_F = -157.4 \text{ [kgf}\cdot\text{cm]}
 \end{aligned}$$

When moving down

$$\begin{aligned}
 T_{Ma2} &= T_a - T_U \cdot \eta^2 + T_F = 295.7 \text{ [kgf}\cdot\text{cm]} \\
 T_{L2} &= -T_U \cdot \eta^2 + T_F = 20.7 \text{ [kgf}\cdot\text{cm]} \\
 T_{Md2} &= -T_d - T_U \cdot \eta^2 + T_F = -254.3 \text{ [kgf}\cdot\text{cm]}
 \end{aligned}$$

7. Setting

When stopping

Unbalance torque $T_U = 65.0$ [kgf·cm]

Since the maximum torque of the HA-SE352 selected provisionally is 510 [kgf·m] or less, both T_{Ma} and T_{Md} are acceptable.

(7) Calculation of continuous effective load torque

$$T_{rms} = \sqrt{\frac{392.6^2 \times 0.24 + 117.6^2 \times 0.52 + (-157.4)^2 \times 0.24 + 65^2 \times 2 \times 2 \times 295.7^2 \times 0.24 + 20.7^2 \times 0.52 + (-254.3)^2 \times 0.24}{3 \times 2}}$$
$$= 131.5 \text{ [kgf·cm]}$$

This is less than the rated torque 170 [kgf·cm] of provisionally selected servo motor HA-SE352 and is therefore acceptable.

(8) Necessity of regenerative option ... Same as that with the SI units system.

Note: When the regenerative energy is calculated to select a regenerative option, the formula for calculating the regenerative energy mentioned in Section 9-4 is as given below.

- During acceleration/deceleration $E_1 = 0.01027 \times N_o \times T_1 \times T_{PSa}$ [J]
- At constant speed $E_2 = \frac{2}{0.01027} \times N_o \times T_1 \times t_1$ [J]

* Torque values T_1 and T_2 are expressed in customary units system [kgf·cm].

8. Troubleshooting

8-1 Troubles shooting points

When the drive is not operating correctly, determine the status of the unit and consider the following items.

⚠ CAUTION

- The MELSERVO-J servo amplifier uses a large capacity, electrolyte capacitor. A voltage will remain in the unit for several minutes after turning the power off, so take care to prevent electrical shocks and short circuits.
- Because of its structure, the servo amplifier does not allow internal energization check. This check must not be made.
- Megger tests must not be conducted. Otherwise, the servo amplifier may be damaged.

Items to consider when problems occur:

- (1) What is the alarm code display?
- (2) Does the error or trouble occur repeatedly? (Check alarm history.)
- (3) Are the servo motor and servo amplifier temperatures and peripheral temperatures normal?
- (4) Is the servo motor accelerating, decelerating, or at a constant speed? What is the speed?
- (5) Is there a difference between the forward and reverse operation?
- (6) Has an instantaneous power failure occurred?
- (7) Does the trouble occur at a certain operation or command?
- (8) How frequently does the trouble occur?
- (9) Does the trouble occur when a load is applied or removed?
- (10) Have parts been replaced or repaired?
- (11) How many years has the unit been operating?
- (12) Is the power voltage normal? Does it change greatly depending on the time?

8. Troubleshooting

8-2 How to measure the voltage and current of the servo

(1) Measurement of servo motor voltage

The voltage output to the servo motor from the servo amplifier is PWM-controlled, and has a pulse type waveform. Depending on the meter type, the indicated value may differ greatly. Install the following filter when measuring, and use a rectifying voltmeter to measure.

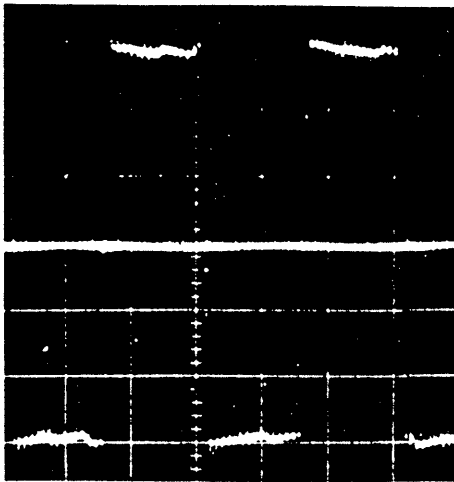
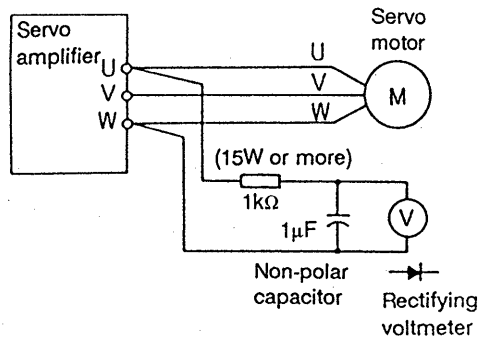

Waveform without filter installed

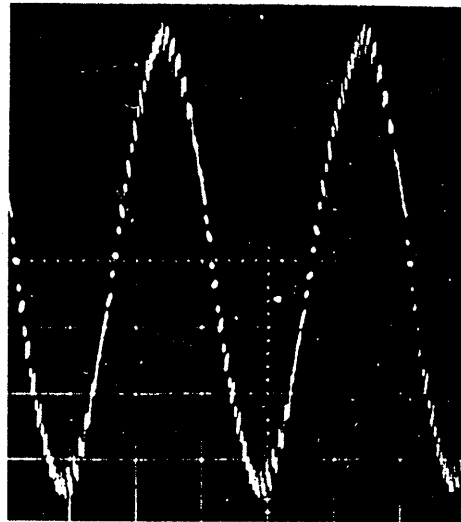

Waveform with filter installed

(2) Measurement of servo motor current

The pulse-shaped current is smoothed to a sinusoidal current with the servo motor reactance. Thus, a moving-iron type ammeter can be directly connected.

(3) Measurement of power

Measure with the three-wattmeter method using an electrodynamicometer.

(4) Other testers

When using an oscilloscope or digital voltmeter, do not ground them. The tester's input current must not exceed 1mA.

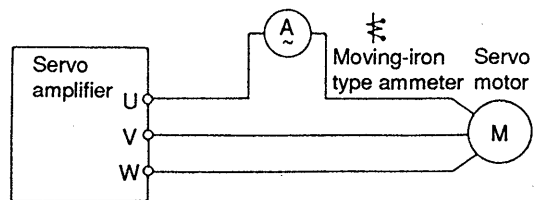

8. Troubleshooting

8-3 Periodic inspection and maintenance

The servo amplifier is a static unit, and requires no daily inspection and maintenance. However, the unit must be inspected at least once a year. The servo motor is brush-less, and maintenance free, but should be inspected periodically to confirm that there are no abnormal sounds or vibrations.

(1) With power on:

- 1) When inspecting while the unit is operating, measure the voltage and current while referring to Section 8-2.
- 2) Check that the fan is operating properly.
- 3) Check that there are no abnormal sounds (servo motor bearing, brake, etc.).

(2) With power off:

- 1) Check to see if any dust or dirt is in the servo amplifier and clean when necessary.
- 2) Check terminal screws for looseness and retighten.
- 3) Check if there are any defects in the parts (discoloration due to overheating, damage, or broken wires, etc.)
- 4) Use a tester (high-resistance range) for the continuity test of the control circuit. Do not use a megger or buzzer.
- 5) Check that there are no scratches or cracks in the cables (especially the detector cable). Carry out the periodic inspection according to the usage conditions for the moving parts.
- 6) Inspect the servo motor shaft and coupling alignment and adjust when necessary.

(3) Parts replacement

The following parts may have mechanical wear or may deteriorate physically after years of use. These can contribute to decreased unit performance and trouble, so periodic maintenance and periodic replacement should be done to maintain performance.

- 1) Smoothing capacitor: The effectiveness will deteriorate because of effects from the ripple current. The life of the capacitor will differ greatly according to the ambient temperature and usage conditions. When operated under normal environmental conditions, the life should be approximately 10 years. The deterioration of the capacitor will be sudden after a certain point is passed. Therefore, periodic inspections should be enforced at least once a year (once every six months when nearing the life of the unit).

The appearance inspection points are as follows:

- a. State of the case: expansion of the case sides and bottom.
- b. State of the sealing plate: visible warping and extreme cracks
- c. State of the explosion-proof valve: remarkable expansion in the valve or valve operated

Periodically check the capacitor for outer appearance, cracks, discoloration, and leakages.

When the measured capacity is below 85% of the rating, the life of the capacitor is judged to be expired.

8. Troubleshooting

- 2) Relays : Defective contacts may occur due to high switching current. The life of relay will differ depending on the power capacity, but the guideline for the life should be 100,000 cycles of operation.
- 3) Servo motor bearing : Replace the bearing after 20,000 to 30,000 hours of normal use under the rated speed and rated load. This will differ on the operation conditions, but the motor bearings should be replaced when abnormal sounds and vibrations are found.
- 4) Cooling fan : Life expectancy of the bearing is 10,000 to 35,000 hours of operation. If continuously operated, replace the cooling fan assembly every two or three years. The cooling fan assembly must be replaced if it makes abnormal sound or vibration. (This applies to MR-J200A and J350A.)

Standard replacement intervals of parts

Part name	Standard replacement interval	Replacement method, etc.
Cooling fan (Note 1)	2 or 3 years	Replace with new part. (Decide according to the result of examination.)
Smoothing capacitor	10 years	Replace the card. (Decide according to the result of examination.)
Relays (Note 1)	—	Same as above
Servo motor bearing	—	Decide according to the result of examination.

Note 1: Applies to MR-J200A and J350.

Table 8.1 Daily inspections and periodical inspections (1/2)

Inspection point	Inspection Item	Inspection object	Inspection period		Inspection method	Judgment criteria	Instrument
			Daily	As specified			
General	Operating environment	Ambient temperature, humidity, dust, etc.	○		Refer to the precautions in Section 1-5.	Refer to Section 1-4 Installation.	Thermometer, hygrometer, recorder
	Storage environment	Ambient temperature, humidity, dust, etc.	○		Measure with a thermometer, hygrometer, etc.	Servo motor: -10°C to +70°C (Freezing is not allowed.) 90%RH or less (Dewing is not allowed.) Servo amplifier: -20°C to +65°C (Freezing is not allowed.) 90%RH or less (Dewing is not allowed.)	Thermometer, hygrometer, recorder
	Overall equipment	Abnormal vibration and sound	○		Visual and hearing check	No abnormality is allowed.	—
	Power supply voltage	Main circuit voltage	○		Measure the voltages between phases R, S and T at the servo amplifier terminal block.	Refer to Section 10-2 Standard specifications.	Digital multimeter

8. Troubleshooting

Table 8.1 Daily inspections and periodical inspections (2/2)

Inspection point	Inspection item	Inspection object	Inspection period		Inspection method	Judgment criteria	Instrument
			Daily	As specified			
Main circuit	General	(1) Looseness at tightened parts (2) Traces of overheat (3) Cleaning		O	(1) Retighten loose parts. (2) Visual check	(1) Loose parts are not allowed. (2) No abnormality is allowed.	
	Connected conductors and wires	(1) Deformed conductor (2) Breaks of wire insulation		O	(1) (2) Visual check	(1) (2) No abnormality is allowed.	
	Terminal block	Damages		O	Visual check	No abnormality is allowed.	
	Smoothing capacitor	(1) Fluid leak (2) Safety valve protruding, swelling (3) Static capacity measurement		O	(1) (2) Visual check (3) Measure with a capacity meter.	(1) (2) No abnormality is allowed. (3) 85% or over of rated capacity	Capacity meter
	Relay	(1) Stick-slip noise at operation (2) Timer operation time (3) Damages at contacts		O	(1) Hearing check (2) Time from power ON to relay ON. (3) Visual check	(1) No abnormality is allowed. (2) Relay must operate in 0.1 to 0.15 sec. (3) No abnormality is allowed.	Universal counter
	Resistor	(1) Crack in the resistor insulation (2) Disconnection		O	(1) Visual check. Cement resistors, coil resistors. (2) Remove connection on one end and measure with a multimeter.	(1) No abnormality is allowed. (2) Error must be within $\pm 10\%$ of indicated resistance value.	Digital multimeter
Control circuit, protective circuit	Operation check	(1) Operate the servo amplifier without applying load and check the balance of voltage between phases. (2) Perform sequence protective operation and check the protective and display circuits.		O	(1) Measure voltages between phases U, V and W of the servo amplifier output terminals. (2) Short the protective circuit output of the servo amplifier.	(1) Balance of the voltages between phases must be within 4V. (2) A sequence error must be generated.	Digital multimeter, rectifier voltmeter
Cooling system	Cooling fan	(1) Abnormal vibration and sound (2) Looseness of connecting parts		O	(1) Turn the fan by hand when the power is not supplied. (2) Retighten.	(1) The fan must rotate smoothly. (2) No abnormality is allowed.	
Indication	Indication	Breaks of the charge lamp and the 7-segment LED indicator		O	Lamp and indicator on the servo amplifier	Make sure the indicators light.	
Servo motor	General	(1) Abnormal vibration and sound (2) Abnormal smell		O	(1) Heating, touching and visual checks (2) Check for abnormal smell by overheat or damage.	(1) (2) No abnormality is allowed.	
	Detector	Abnormal vibration and sound		O	Hearing and touching	No abnormality is allowed.	
	Cooling fan	(1) Abnormal vibration and sound (2) Adhesion of mist and foreign material		O	(1) Turn the fan by hand when the power is not supplied. (2) Visual check	(1) Must rotate smoothly. (2) No abnormality is allowed.	
	Bearing	Abnormal vibration and sound		O	Hearing and touching	No abnormality is allowed.	

8. Troubleshooting

8-4 Alarms

When an alarm occurs, the trouble signal (ALM) in the servo amplifier will switch OFF. Therefore, the magnetic contactor (MC) installed before the input terminals (R, S, T) will switch OFF, and the servo amplifier power will be shut off. The alarm will be displayed for several seconds, but after that, will switch off. To confirm which alarm occurred, switch the power ON again, and check the alarm history. Alternatively preset the alarm code outputs in parameter No. 19. The DO output alarm code will then be read into the host controller when an alarm occurs.

LED display Alarm code	DO output alarm code			Alarm name	Alarm details	Alarm occurrence time	Possibility of reset alarm with reset signal	Cause	Points to check	Remedy	
	CN1 pin No.										
	26	25	24								
12	0	0	0	Memory error 1	RAM, ROM memory error	When power is switched ON	Not possible	Error in unit part		Replace unit.	
15				Memory error 2	EEPROM memory error						
17				PCB error	CPU, part error						
37				Parameter error	Parameter value is wrong.						Parameter has been rewritten.
10	0	1	0	Undervoltage	Power voltage has dropped. (200V class: 165V or less 100V class: 83V or less)	Alarm occurs when power is switched ON.	Possible	1. Power voltage is low. 2. Power was switched ON immediately after it was switched OFF.	Check the input terminal (R, S, T) voltage with tester or synchroscope.	Review the power supply.	
						Alarm occurs during acceleration or when load is applied.					Insufficient power capacity
						During operation					Instantaneous power failure (10 msec or more)
16	0	1	1	Polarity detect error (RD)	The servo motor polarity cannot be detected normally.	Alarm occurs when power is switched ON.	Possible	Encoder connector is disconnected.	Visually check for disconnected connector.	Connect properly.	
								Defective encoder cable connection	Check that the encoder signals (PU, PUR, PV, PVR, PW, PWR) are correctly connected.		

Continued on the next page.

8. Troubleshooting

LED display Alarm code	DO output alarm code			Alarm name	Alarm details	Alarm occurrence time	Possibility of reset alarm with reset signal	Cause	Points to check	Remedy	
	CN1 pin No.										
	26	25	24								
16	0	1	1	Polarity detect error (RD)	The servo motor polarity cannot be detected normally.	Alarm occurs when power is switched ON.	Possible	Defective encoder or servo amplifier	1. When other motors and amplifiers are used: alternate the servo motors and servo amplifiers to find the defective unit. 2. Check the signals in the connector: Check whether "H" or "L" occurs simultaneously in PU, PV and PW.	Replace unit.	
					There is a bend in the cable that corresponds to the servo motor rotation Alarm occurs at specific position.	Is the cable broken?		Bend the cable and check for continuity.			Replace cable.
30	1	0	0	Over-regeneration (Note 1)	The regenerative transistor is continuously ON.	Alarm occurs when power is switched ON.	Reset is possible, but alarm occurs again immediately.	Regenerative transistor damage	If the alarm occurs immediately after power is switched ON, check the power voltage with a tester. The regenerative transistor is damaged if below 260VAC. Avoid switching the power ON after this. (The regenerative resistor will overheat (dangerous).)	Replace unit.	
					The tolerable loss of the regenerative resistor is exceeded.	During operation (display status L90% or more)	Possible Leave for 3 to 5 min. and wait until display status drops to approx. 50%. Then, reset alarm with reset signal input.	Parameter setting error	Confirm the parameter set values (Pr. 1). (Refer to parameter list.)		Set properly.
								Frequent positioning (regenerative)	Check the regeneration frequency and regenerative resistor loss.		1. Lower the positioning frequency. 2. Increase the regenerative option capacity. 3. Lower the load.
31	1	0	1	Overspeed	The servo motor speed exceeds 115% of the maximum speed.	Alarm occurs other than during acceleration.	Possible	Encoder signal error or servo amplifier error	1. Check cable connection (PA, PAR, PB, PBR, PZ, PZR signals). 2. Alternately change the servo motor and servo amplifier.	Replace the cable. Replace the servo motor. Replace the servo amplifier.	

Continued on the next page.



8. Troubleshooting

LED display Alarm code	DO output alarm code			Alarm name	Alarm details	Alarm occurrence time	Possibility of reset alarm with reset signal	Cause	Points to check	Remedy
	CN1 pin No.									
	26	25	24							
31	1	0	1	Overspeed	The servo motor speed exceeds 115% of the maximum speed.	Alarm occurs during acceleration.	Possible	For position servo 1. For HA-SE servo motor: Pulse train command is 150kpps or more (electronic gear 1/1) 2. The electronic gear ratio is too large. (Pr. 2, 3)	1. Check parameter Pr. 2, 3 settings and command frequency. 2. Check the status display (r, n).	Set correctly.
								For speed servo: Speed command is too large.	The parameter Pr. 9 (speed during 10V command) and analog speed command voltage do not match.	Set correctly.
								Overshoot is too large.	The acceleration/deceleration time constant is too small in the position servo and the motor overshoots during acceleration. Check status display (b).	Review the acceleration/deceleration time constant.
								Overshoot is too large due to unstable servo system.	1. Try automatic tuning. 2. Adjust the servo gain. VGN: increase VIC: increase PGN: decrease 3. Check whether the alarm occurs when the speed is decreased.	Correctly adjust the gain.
32	0	0	1	Overcurrent	The current to the servo amplifier exceeds tolerable value.	Alarm occurs when servo is switched ON.	Possible	The servo amplifier's output terminals (U, V, W) are short circuited.	Check whether the output terminals are short circuited.	Correct the wiring.
								The servo amplifier's output terminals (U, V, W) are in ground fault.	Check insulation between the output terminals and case with a tester.	Correct the wiring.
								External noise	Check the peripheral equipment (AL-32 occurs when the relay or valves are operating).	Enforce noise countermeasures.
								Servo amplifier IPM defect	Disconnect the output cables (U, V, W) and switch the servo ON.	Replace the unit.
						Alarm occurs at certain intervals during the operation or when servo is OFF.				
						Alarm occurs when servo is switched ON.				

Continued on the next page.

8. Troubleshooting

LED display Alarm code	DO output alarm code			Alarm name	Alarm details	Alarm occurrence time	Possibility of reset alarm with reset signal	Cause	Points to check	Remedy
	CN1 pin No.									
	26	25	24							
32	0	0	1	Overcurrent	A current exceeding the tolerable value is flowing to brake TR (MR-J100A and higher models).	Alarm occurs during servo motor deceleration.	Possible	Regenerative option installed is not proper.	Check that the regenerative option resistivity value matches the unit.	Replace the regenerative option.
33	1	0	0	Overvoltage (OV)	The converter's d.c. line voltage exceeds 400VDC.	Alarm occurs other than during servo motor deceleration.	Possible	Power supply voltage too large.	Check the power voltage with a tester.	Review the power.
								Power voltage distortion is too large (when regenerative option is not installed).	Measure power voltage waveform with an oscilloscope and check for power voltage distortion.	1. Install the FR-BAL. 2. Use a different power source from the equipment where distortion is occurring.
								Regenerative energy is too large (when regenerative option is not installed).	Check the regenerative energy.	Install the regenerative option.
								Broken wire in regenerative resistor	Check the regenerative resistor resistance value with a tester. MR-RBOO□ Resistance value 0: 13Ω 3: 52Ω 4: 26Ω	Replace the regenerative option.
								The regenerative resistor is incorrect (especially in models MR-J200A or upper).	Check that the regenerative option and unit match.	Replace the regenerative option.
35	1	0	1	Error in the command frequency	The pulse train command frequency exceeds 220Kpps (only in the position servo).	Alarm occurs during operation other than in high speed rotation.	Possible	Servo amplifier error	—	Replace unit.
						Alarm occurs during high speed rotation or acceleration.		Pulse train command exceeds 220Kpps.		

Continued on the next page.

8. Troubleshooting

LED display Alarm code	DO output alarm code CN1 pin No.			Alarm name	Alarm details	Alarm occurrence time	Possibility of reset alarm with reset signal	Cause	Points to check	Remedy
	26	25	24							
45	1	1	0	Main circuit element overheating	The servo amplifier's main circuit element (IPM) is overheating. (100°C to 120°C)	Alarm occurs when servo is ON and motor is not operating.	Possible (Reset alarm with reset input after main circuit element temperature has dropped.)	Servo amplifier error	—	Replace the unit.
								Cooling defect	<ol style="list-style-type: none"> 1. Check whether the servo amplifier's fan is stopped (in models exceeding MR-J200A). 2. Check whether the ventilation is obstructed. 3. Check whether the temperature in the box is too high. 4. Check the status display (J). 	Improve the cooling condition.
								Operation was performed so that AL-50 does not operate (power ON/OFF was repeated).	Is it operated by turning the power ON/OFF repeatedly?	Review operation methods.
50	1	1	0	Overload (Note 1)	A current exceeding the electronic thermal curve has flowed.	Alarm at servo ON.	Possible Reset with the reset input signal after 3 to 5 min. have passed from the alarm and the status display J has dropped to approx. 50% or below.	The servo amplifier output terminals (U, V, W) and servo motor terminals (U, V, W) do not match.	<ol style="list-style-type: none"> 1. Check the U, V, W connections. 2. Check the status display J. 	Connect properly.
								Hunting occurs due to unstable servo system.	Same as alarm code AL-31	
								Encoder signal defect	Same as alarm code AL-16 and 31	
								The machine struck something.	Same as alarm code AL-52	
								A load exceeding the servo capacity has been used.	Check status display J.	<ol style="list-style-type: none"> 1. Review capacity. 2. Review operation pattern.
52	1	0	1	Excessive difference	The remaining pulses in the deviation counter exceed 65K pulses.	During positioning servo acceleration	Possible	The position loop gain (Pr. 5) is too small, and the overshoot during acceleration is too large.	<ol style="list-style-type: none"> 1. Check parameter (Pr. 5). 2. Check acceleration time constant. 3. Check gain. 4. Try automatic tuning. 	Review the parameters.
								The servo motor is rotated with external force.	<ol style="list-style-type: none"> 1. Check status display (E, L). Check whether the status display (E, L) changes when servo motor is stopped. 2. Check torque limit command. Is the servo torque set to a small value with an external force? 3. Recheck the servo motor capacity. 	<ol style="list-style-type: none"> 1. Change the torque limit command. 2. Change the motor capacity.

Continued on the next page.

8. Troubleshooting

LED display Alarm code	DO output alarm code			Alarm name	Alarm details	Alarm occurrence time	Possibility of reset alarm with reset signal	Cause	Points to check	Remedy
	26	25	24							
52	1	0	1	Excessive difference	The remaining pulses in the deviation counter exceed 65K pulses.	When positioning servo command is applied	Possible	The machine struck something.	Check whether a machine has been contacted. (P in the status display has changed but L has not.)	Review the operation pattern.
								The output terminals (U, V, W) are not connected properly.	Check that the servo motor and servo amplifier (U, V, W) terminals match.	Correct the wiring.
								Encoder signal defect	Same as alarm code AL-16	
90	1	1	1	Switch to diagnosis display while servo is on.	Servo ON signal is ON when no-motor operation is set.	—	Possible	Servo ON signal is ON.	Check whether the servo ON signal is ON.	Set after turning servo-ON signal OFF.
					Alarm code is not output.			Servo ON signal is ON when switching to the do (output signal) check screen or test mode operation screen.	Possible	Same as above
CPU	Not defined			CPU error	CPU is not operating correctly.	—	Not possible	CPU is not operating correctly.	Try resetting the power.	Replace the unit.
CO	Alarm code is not output.			Communication error (the motor operates normally even when this alarm is output)	Communication error has occurred between servo CPU and display CPU.	—	Not possible	Servo amplifier defect	Unit error if not corrected when power is reset	Replace the unit.
								External noise	Same as alarm code AL-32	

(Note) Once alarm AL-30 or AL-50 occurs, its alarm status is stored in the EEPROM. Therefore, the time until the next alarm occurs after the power is reset is shortened. The status display J and L values will be approximately 80% when the power is reset after an alarm. To reset the stored alarm status, switch the servo-ON signal OFF, or stay in the non-load status for 3 to 5 minutes. Lower the status display J and L to approximately 40% or below. Operation with an effective load of under 100% is possible even when the alarm status is stored.

8. Troubleshooting

8-5 Determining the cause of a position offset

- Position servo -

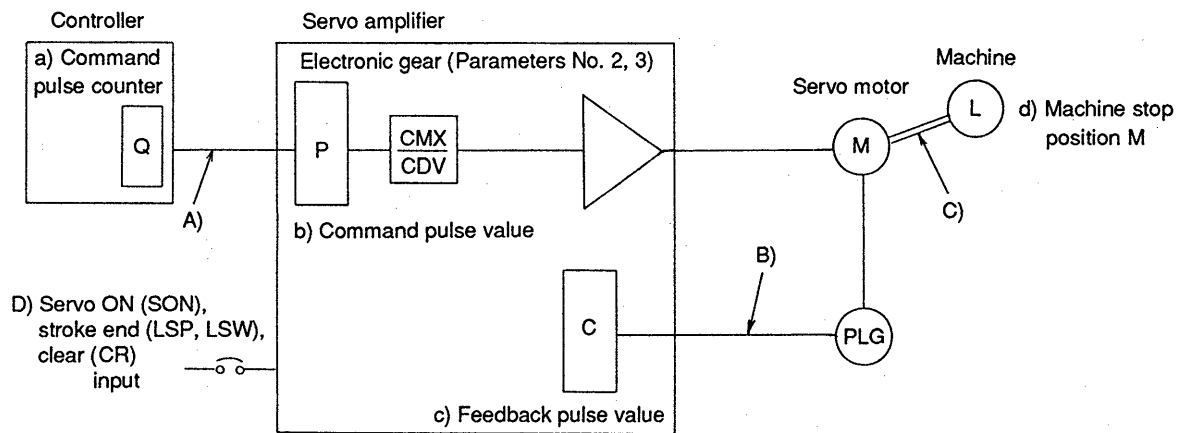

In the above diagram, (a) command pulse counter, b) command pulse value P display, c) feedback pulse value C display, and d) machine stop position represent points to be checked when a position offset occurs.

Also, A, B, C and D indicate places where position offset factors may occur. For example, A, indicates the wiring between the controller and servo amplifier where noise may be picked up. The noise may cause the mis-count of pulses.

In a normal operation without a position offset, the following relationships are established and maintained:

- 1) $Q = P$ (command pulse counter value of the controller = servo amplifier command pulse value)
- 2) $P \times \frac{CMX (Pr.2)}{CDV (Pr.3)} = C$ (command pulse value \times electronic gear ratio = feedback pulse value)
- 3) $C \times \Delta l = M$ (feedback pulse value \times movement amount per feedback pulse = machine position)

When a position offset occurs, check the following situations:

- 1) When $Q \neq P$
Noise picked up by the pulse train signal wiring between the controller and servo amplifier may have caused a pulse count error. (Factor A)
- 2) When $P \times \frac{CMX}{CDV} \neq C$
The servo ON (SON) signal or forward/reverse run stroke end (LSP, LSN) signal may have switched off during operation, or the clear (CR) signal switched ON. (Factor D)
- 3) When $C \times \Delta l \neq M$
Noised picked up by the encoder cable may have caused a count error, or mechanical slip may have occurred between the servo motor and machine.